

# ST. LUCIE COUNTY UTILITIES

## WATER, WASTEWATER & RECLAIMED WATER CONSTRUCTION DETAILS



### ST. LUCIE COUNTY UTILITIES

2300 Virginia Avenue

Ft. Pierce, FL 34982

Phone (772) 462-1150

Fax (772) 462-1153

December 2019

## **GENERAL**

- G-1 GENERAL NOTES AND SPECIFICATIONS I
- G-2 GENERAL NOTES AND SPECIFICATIONS II
- G-3 GENERAL NOTES AND SPECIFICATIONS III
- G-4 GENERAL NOTES AND SPECIFICATIONS IV
- G-5 TYPICAL TRENCH DETAIL
- G-6 CONCRETE PAVEMENT REPLACEMENT
- G-7 FLEXIBLE PAVEMENT REPLACEMENT DETAIL
- G-8 UTILITY ROAD CUT PAVEMENT RESTORATION
- G-9 RESTRAINED JOINT SCHEDULE
- G-10 THRUST BLOCK DETAIL
- G-11 ADDITIONAL THRUST BLOCK REQUIREMENTS
- G-12 JACK AND BORE CASING INSTALLATION DETAIL
- G-13 TRACER WIRE DETAIL
- G-14 PROTECTIVE SLAB FOR PIPE
- G-15 PRESSURE PIPE CONFLICT DETAIL
- G-16 VALVE SETTING DETAIL (GATE VALVE)
- G-17 VALVE SETTING DETAIL (BUTTERFLY/PLUG VALVE)
- G-17B TYPICAL VALVE BOX AND COLLAR DETAIL
- G-18 AIR VALVE AND BOX (POTABLE/RECLAIMED)
- G-19A AIR VALVE AND ENCLOSURE PLAN (WASTEWATER)
- G-19B AIR VALVE AND ENCLOSURE SIDE ELEVATION (WASTEWATER)
- G-19C AIR VALVE AND ENCLOSURE FRONT ELEVATION (WASTEWATER)
- G-20 UNDERGROUND AIR RELEASE VALVE AND BOX (MANUAL)
- G-21 SUBAQUEOUS CROSSING DETAIL
- G-22 TYPICAL UTILITIES CANAL CROSSING
- G-23 FAN GUARD DETAIL
- G-24 FENCE DETAIL
- G-25 SIDEWALK DETAILS

G-26 AIR GAP SEPERATION DETAIL

**POTABLE WATER**

- W-1 TEMPORARY SAMPLE POINT DETAIL (INLINE)
- W-2 TEMPORARY SAMPLE POINT DETAIL (FIRE HYDRANT)
- W-3 FLUSHING HYDRANT DETAIL
- W-4 TEMPORARY BLOW-OFF W/ RESTRAINT
- W-5 CANNON FLUSHING PROCEDURE
- W-6 FIRE HYDRANT INSTALLATION DETAIL
- W-7 SERVICE CONNECTION DETAIL 5" OR 1" METER
- W-8 WATER SERVICE CONNECTIONS PLAN/PROFILE
- W-9 TYPICAL CONNECTION FOR MULTIPLE SERVICES (THREE OR MORE)
- W-10 WATER SERVICE TAP UNDER PAVEMENT
- W-11 PROTECTIVE ENCLOSURE FOR ABOVE GROUND DEVICES
- W-12 2" METER DETAIL
- W-13 TYPICAL ABOVE GROUND METER 3" OR LARGER
- W-14 FIRE LINE DOUBLE DETECTOR CHECK VALVE
- W-15 BACFLOW PREVENTER SINGLE SERVICE 4", 6" & 8"
- W-16 PRIVATE BACKFLOW DEVICE
- W-17 PRESSURE-TYPE VACUUM BREAKER (P.V.B.)
- W-18 TEMORARY JUMPER DETAIL & SCHEDULE
- W-19 DOUBLE VALVE DETAIL AND FILLING & FLUSHING CONNECTION

**SEWER**

- S-1 SANITARY SEWER LATERAL DETAIL
- S-2 SEWER SERVICE CLEANOUT DETAIL
- S-2B SHROUD FOR SEWER CLEANOUT ASSEMBLY DETAIL
- S-3 MANHOLE FRAME AND COVER DETAIL
- S-4 WASTEWATER RAIN GUARD DETAIL
- S-5 STANDARD PRECAST MANHOLE DETAIL

- S-6 FLAT TOP PRECAST MANHOLE DETAIL FOR SHALLOW MANHOLES
- S-7 DOGHOUSE MANHOLE DETAIL
- S-8 INVERT FLOW CHANNEL DETAIL
- S-9 INSIDE DROP MANHOLE
- S-10 CONFLICT MANHOLE DETAIL
- S-11 FORCE MAIN ENTERING SHALLOW MANHOLE
- S-12 FORCE MAIN ENTERING DEEP MANHOLE
- S-13 DOUBLE-COMPARTMENT GREASE TRAP & OIL SEPARATOR
- S-14 TYPICAL LIFT STATION PLAN (SMALL)
- S-15 TYPICAL LIFT STATION PLAN (LARGE)
- S-16 TYPICAL LIFT STATION SECTION
- S-17 TYPICAL LIFT STATION DATA
- S-18 LIFT STATION TREMIE POUR DETAIL
- S-19 WET WELL SECTION RETAINER STRAP
- S-20 STANDARD ALUMINUM COVER
- S-21 WASHDOWN HYDRANT AT LIFT STATION
- S-22 TYPICAL LIFT STATION CONTROL PANEL (FRONT VIEW)
- S-23 TYPICAL LIFT STATION CONTROL PANEL (BACK VIEW)
- S-24 LIFT STATION CONTROL PANEL NOTES

## **REUSE**

- RU-1 REUSE WATER METERING FACILITY PLAN (POND DISCHARGE)
- RU-2 REUSE WATER METERING FACILITY SECTION (POND DISCHARGE)
- RU-3 REUSE WATER METERING FACILITY PLAN (BULK USER)
- RU-4 REUSE WATER METERING FACILITY METERING FACILITY SECTION (BULK USER)
- RU-5 REUSE WATER SYSTEM SIGNAGE

## GENERAL NOTES

### UTILITY CONSTRUCTION NOTES

UTILITY CONSTRUCTION NOTES SHALL BE PROVIDED IN THE DRAWING SET AS FOLLOWS (NOTE: SHOW ALL NOTES IN THE FOLLOWING ORDER):

#### GENERAL

1. ALL CONSTRUCTION MATERIALS AND METHODS FOR POTABLE WATER, WASTEWATER, AND RECLAIMED WATER SYSTEMS SHALL BE IN ACCORDANCE WITH THE DISTRICT DESIGN CRITERIA AND SPECIFICATIONS, THE DISTRICT CONSTRUCTIONS STANDARDS.
2. THE CONTRACTOR SHALL COMPLY WITH ALL CONDITIONS AND REQUIREMENTS OF ALL PERMITS OBTAINED FOR THE PROJECT.
3. ALL MATERIALS USED ON THE PROJECT SHALL IN LISTED IN THE DISTRICT APPROVED MATERIAL LIST.
4. THE CONTRACTOR SHALL HAVE AVAILABLE AT THE JOB SITE ONE CURRENT COPY OF DISTRICT DESIGN CRITERIA AND SPECIFICATIONS, DISTRICT CONSTRUCTIONS STANDARDS, AND THE CONTRACT DRAWINGS AT ALL TIMES.
5. THE CONTRACTOR SHALL OBTAIN THE SERVICES OF A PROFESSIONAL LAND SURVEYOR LICENSED IN THE STATE OF FLORIDA FOR LAYOUT.
6. ALL MATERIALS, COATINGS, AND CHEMICALS THAT CONTACT DRINKING WATER SHALL BE IN CONFORMANCE WITH ANSI/NSF STANDARD 61.
7. MAILBOXES SHALL BE CAPABLE OF RECEIVING MAIL AT ALL TIMES.

#### REFERENCED DATA

8. ALL ELEVATIONS ARE REFERENCED TO NATIONAL GEODETIC VERTICAL DATUM (NGVD) 1988. THE HORIZONTAL DATUM IS BASED ON STATE PLANE EAST, NORTH AMERICAN DATUM (NAD) 1983.

#### EXISTING CONDITIONS

9. LOCATIONS, ELEVATIONS, DIMENSIONS, AND MATERIAL OF EXISTING UTILITIES ARE BASED ON THE BEST INFORMATION AVAILABLE AT THE TIME OF THE PREPARATION OF THESE DRAWINGS BUT ARE NOT PURPORTED TO BE ABSOLUTELY CORRECT. THERE MAY BE OTHER UTILITIES IN THE PROJECT AREA. THE CONTRACTOR SHALL VERIFY, PRIOR TO CONSTRUCTION, THE LOCATIONS, ELEVATIONS, DIMENSIONS, AND MATERIAL OF EXISTING UTILITIES (WHETHER OR NOT SHOWN ON THE DRAWINGS) AFFECTING HIS WORK.

#### UTILITY COORDINATION

10. THE CONTRACTOR SHALL NOTIFY ALL UTILITIES NEAR THE PROJECT AREA AT LEAST 48 HOURS PRIOR TO CONSTRUCTION. THIS SHALL INCLUDE NOTIFYING "SUNSHINE STATE ONE CALL OF FLORIDA" AT LEAST 48 HOURS PRIOR TO ANY DIGGING WORK TO HAVE ALL KNOWN EXISTING UTILITIES LOCATED.
11. THE CONTRACTOR SHALL PRESERVE AND MAINTAIN EXISTING UTILITIES, STRUCTURES, AND OTHER FEATURES WITHIN THE PROJECT AREA. ANY DAMAGE SHALL BE REPAIRED BY AND AT THE EXPENSE OF THE CONTRACTOR TO THE SATISFACTION OF THE DISTRICT.
12. THE CONTRACTOR IS RESPONSIBLE FOR BRACING, SHORING, OR PROVIDING OTHER MEANS NECESSARY TO PROTECT AND SUPPORT EXISTING UTILITIES, STRUCTURES, AND OTHER FEATURES (EXPOSED OR UNEXPOSED) THAT MAY BE IMPACTED BY HIS WORK.



ST. LUCIE COUNTY  
WATER & WASTEWATER  
CONSTRUCTION  
STANDARDS

GENERAL NOTES AND  
SPECIFICATIONS I (1 - 12)

DATE APPROVED: DECEMBER 2015

DRAWING NUMBER:

G-1

## GENERAL NOTES (Cont.):

### PIPING

13. ALL CONNECTIONS TO EXISTING MAINS SHALL BE OBSERVED BY THE DISTRICT. VALVES ON EXISTING MAINS SHALL BE OPERATED BY DISTRICT PERSONNEL OR UNDER THEIR DIRECT SUPERVISION. TAPPING SLEEVES AND VALVES SHALL BE PRESSURE TESTED PRIOR TO TAPPING. IF SERVICE MUST BE CUT OFF TO EXISTING CUSTOMERS, THE DISTRICT SHALL BE NOTIFIED AT LEAST THREE DAYS IN ADVANCE TO MAKE NECESSARY NOTIFICATIONS. IN THIS EVENT THE CONTRACTOR SHALL BE READY TO PROCEED WITH AS MUCH MATERIAL REASSEMBLED AS POSSIBLE AT THE SITE TO MINIMIZE THE LENGTH OF SERVICE INTERRUPTION. THE DISTRICT WILL POSTPONE A SERVICE CUT-OFF IF THE CONTRACTOR IS NOT READY TO PROCEED ON SCHEDULE. SUCH CONNECTIONS SHALL BE MADE AT NIGHT TO MINIMIZE EFFECTS UNLESS OTHERWISE AUTHORIZED BY THE DISTRICT. NO CUSTOMERS SHALL BE WITHOUT SERVICE FOR MORE THAN FOUR HOURS.
14. DENSITY TESTS OF TRENCH BACKFILL MATERIAL SHALL BE REQUIRED AT THE TRENCH BOTTOM AND EACH LIFT OF BACKFILL AT INTERVALS OF NO MORE THAN 500 FEET. DENSITY TESTS OF PAVEMENT OPEN-CUT AREAS INCLUDING ROADS, TURNLANES, AND DRIVES SHALL BE REQUIRED AT INTERVALS OF NOT MORE THAN 50 FEET. COMPACTION SHALL BE IN ACCORDANCE WITH THE "TYPICAL TRENCH DETAIL" AND "FLEXIBLE PAVEMENT REPLACEMENT DETAIL". A CERTIFIED COPY OF TESTS SHALL BE PROVIDED TO THE DISTRICT. DENSITY TESTING CONDUCTED BY AN INDEPENDENT TESTING LAB APPROVED BY THE DISTRICT.
15. MINIMUM COVER TO FINISHED GRADE OVER MAINS SHALL BE 30" FOR PIPE UP TO 8" DIAMETER, 36" FOR 10" TO 12" PIPE, AND 48" FOR 14" AND LARGER PIPE.
16. ALL BURIED PIPING SHALL BE RESTRAINED IN ACCORDANCE WITH THE RESTRAINED JOINT SCHEDULE DETAIL.
17. ALL PRESSURE TESTS SHALL BE IN ACCORDANCE WITH THE ST. LUCIE COUNTY UTILITIES DISTRICT CONSTRUCTION STANDARDS AND TECHNICAL SPECIFICATIONS AND AWWA STANDARDS (LATEST EDITIONS).
18. THE CONTRACTOR SHALL CLEAN MAINS BY FLUSHING OR USING APPROVED POLYURETHANE PIG(S). TEMPORARY CLEANING STATIONS SHALL BE CONSTRUCTED BY THE CONTRACTOR. THE CONTRACTOR SHALL PROVIDE A CLEANING PLAN SHOWING THE METHOD OF FILLING AND CLEANING MAINS PRIOR TO THE START OF CONSTRUCTION. THE CLEANING PLAN SHALL BE APPROVED BY THE DISTRICT PRIOR TO CONSTRUCTION. ALL COSTS FOR FILLING AND CLEANING SHALL BE A THE CONTRACTORS EXPENSE.
19. WATER SERVICES SHALL BE INSTALLED BY JACK AND BORE, HORIZONTAL DIRECTIONAL DRILL, OR MOLING METHODS. JETTING OF SERVICE LINES SHALL NOT BE PERMITTED.

### SEPARATIONS

20. POTABLE WATER SEPARATION:
  - a. FOR PARALLEL INSTALLATIONS, WATER MAINS SHALL BE LAID WITH A MINIMUM OF 10 FEET HORIZONTAL SEPARATION, EDGE-OF-MAIN TO EDGE-OF-MAIN
  - b. FOR WATER MAINS CROSSING SEWERS, A MINIMUM OF 18 INCHES SHALL BE MAINTAINED FROM THE OUTSIDE OF WATER MAIN TO THE OUTSIDE OF SEWER MAIN. AT THE CROSSING, ONE FULL-LENGTH OF WATER MAIN PIPE SHALL BE LAID IN SUCH A WAY THAT BOTH JOINTS WILL BE AS FAR FROM THE SEWER MAIN AS POSSIBLE. SANITARY SEWERS, FORCE MAINS, AND STORM SEWERS SHOULD CROSS UNDER WATER MAINS, WHEREVER POSSIBLE.



ST. LUCIE COUNTY  
WATER & WASTEWATER  
CONSTRUCTION  
STANDARDS

GENERAL NOTES AND  
SPECIFICATIONS II (13 - 20)

DATE APPROVED: DECEMBER 2015

DRAWING NUMBER:

G-2

GENERAL NOTES (Cont.)

- c. WHERE IT IS NOT PRACTICAL TO MEET THESE PARAMETERS, SPECIFIC REQUIREMENTS FROM THE REGULATORY AGENCIES MUST BE FOLLOWED.
- d. HORIZONTAL SEPARATIONS OF 15 FEET TO BUILDINGS, TREES, TOP-OF-BANKS OF LAKES AND CANALS AND OTHER STRUCTURES SHALL BE MAINTAINED.

21. HORIZONTAL SEPARATION:

- a. WATER MAINS SHALL BE LAID WITH A MINIMUM OF 10 FEET HORIZONTAL SEPARATION, EDGE-OF-MAIN TO EDGE-OF-MAIN, FROM EXISTING AND PROPOSED SEWERS.
- b. WATER MAINS SHALL BE LAID WITH A MINIMUM OF 3 FEET HORIZONTAL SEPARATION, EDGE-OF-MAIN TO EDGE-OF-MAIN, FROM EXISTING AND PROPOSED STORM SEWERS AND RECLAIMED WATER MAINS.
- c. HORIZONTAL SEPARATIONS OF 15 FEET TO BUILDINGS, TREES, TOP-OF-BANKS OF LAKES AND CANALS AND OTHER STRUCTURES SHALL BE MAINTAINED.
- d. WHERE IT IS NOT PRACTICAL TO MEET THESE PARAMETERS, SPECIFIC REQUIREMENTS FROM THE REGULATORY AGENCIES MUST BE FOLLOWED.

22. VERTICAL SEPARATION:

- a. FOR WATER MAINS CROSSING SEWERS, A MINIMUM OF 18 INCHES SHALL BE MAINTAINED FROM THE OUTSIDE OF WATER MAIN TO THE OUTSIDE OF SEWER MAIN. AT THE CROSSING, ONE FULL-LENGTH OF WATER MAIN PIPE SHALL BE LAID IN SUCH A WAY THAT BOTH JOINTS WILL BE AS FAR FROM THE SEWER MAIN AS POSSIBLE.
- b. FOR WATER MAINS CROSSING STORM SEWERS AND RECLAIMED WATER MAINS, A MINIMUM OF 12 INCHES SHALL BE MAINTAINED FROM THE OUTSIDE OF WATER MAIN TO THE OUTSIDE OF SEWER MAIN. AT THE CROSSING, ONE FULL-LENGTH OF WATER MAIN PIPE SHALL BE LAID IN SUCH A WAY THAT BOTH JOINTS WILL BE AS FAR FROM THE STORM SEWER OR RECLAIMED WATER MAIN AS POSSIBLE.
- c. SANITARY SEWERS, FORCE MAINS, AND STORM SEWERS SHOULD CROSS UNDER WATER MAINS, WHEREVER POSSIBLE.
- d. WHERE IT IS NOT PRACTICAL TO MEET THESE PARAMETERS, SPECIFIC REQUIREMENTS FROM THE REGULATORY AGENCIES MUST BE FOLLOWED.

MAINTENANCE OF TRAFFIC

- 23. THE CONTRACTOR SHALL BE RESPONSIBLE FOR SAFE MAINTENANCE OF PEDESTRIAN AND VEHICULAR TRAFFIC AT ALL TIMES DURING THE DURATION OF THE PROJECT.
- 24. THE CONTRACTOR SHALL MAINTAIN TRAFFIC IN ACCORDANCE WITH FDOT STANDARD INDEX 600 SERIES AND THE TECHNICAL SPECIFICATIONS. THE CONTRACTOR SHALL FURNISH, ERECT, AND MAINTAIN ALL NECESSARY TRAFFIC CONTROL AND SAFETY DEVICES THROUGHOUT THE PROJECT.

DEWATERING AND EROSION CONTROL

- 25. THE CONTRACTOR IS RESPONSIBLE FOR OBTAINING A DEWATERING PERMIT THROUGH THE SOUTH FLORIDA WATER MANAGEMENT DISTRICT SHOULD DEWATERING ACTIVITIES BE REQUIRED.
- 26. THE CONTRACTOR SHALL BE RESPONSIBLE FOR THE SELECTION, INSTALLATION, MAINTENANCE, AND SATISFACTORY OPERATION OF THE EROSION AND SEDIMENT CONTROL DEVICES/SYSTEM IN ACCORDANCE WITH SFWMD REQUIREMENTS



ST. LUCIE COUNTY  
WATER & WASTEWATER  
CONSTRUCTION  
STANDARDS

GENERAL NOTES AND  
SPECIFICATIONS III (20 -26)

GENERAL NOTES (Cont.):

27. ANY DISCHARGE FROM DEWATERING ACTIVITIES SHALL BE FILTERED AND CONVEYED TO A SEDIMENTATION BASIN IN A MANNER WHICH PREVENTS EROSION AND TRANSPORTATION OF SUSPENDED SOLIDS TO OUTFALLS.
28. THE CONTRACTOR SHALL REMOVE THE DEWATERING AND EROSION CONTROL AND SEDIMENT CONTROL DEVICES/SYSTEMS AFTER COMPLETION OF CONSTRUCTION AND ONLY WHEN THE AREAS HAVE BEEN STABILIZED.

RESTORATION

29. ALL PAVING, STABILIZED EARTH, DRIVEWAYS, CURBS, SIDEWALKS, FENCES, SOD, LANDSCAPING, CULVERTS, ETC. DISTURBED BY CONSTRUCTION ACTIVITIES SHALL BE RESTORED BY AND AT THE EXPENSE OF THE CONTRACTOR TO THE SATISFACTION OF THE DISTRICT.
30. ALL DAMAGED CONCRETE AND ASPHALT DRIVE SHALL BE REPLACED FROM RIGHT-OF-WAY LINE TO EDGE OF PAVEMENT.



ST. LUCIE COUNTY  
WATER & WASTEWATER  
CONSTRUCTION  
STANDARDS

GENERAL NOTES AND  
SPECIFICATIONS IV (27 - 30)

DATE APPROVED: DECEMBER 2015

DRAWING NUMBER:

G-4



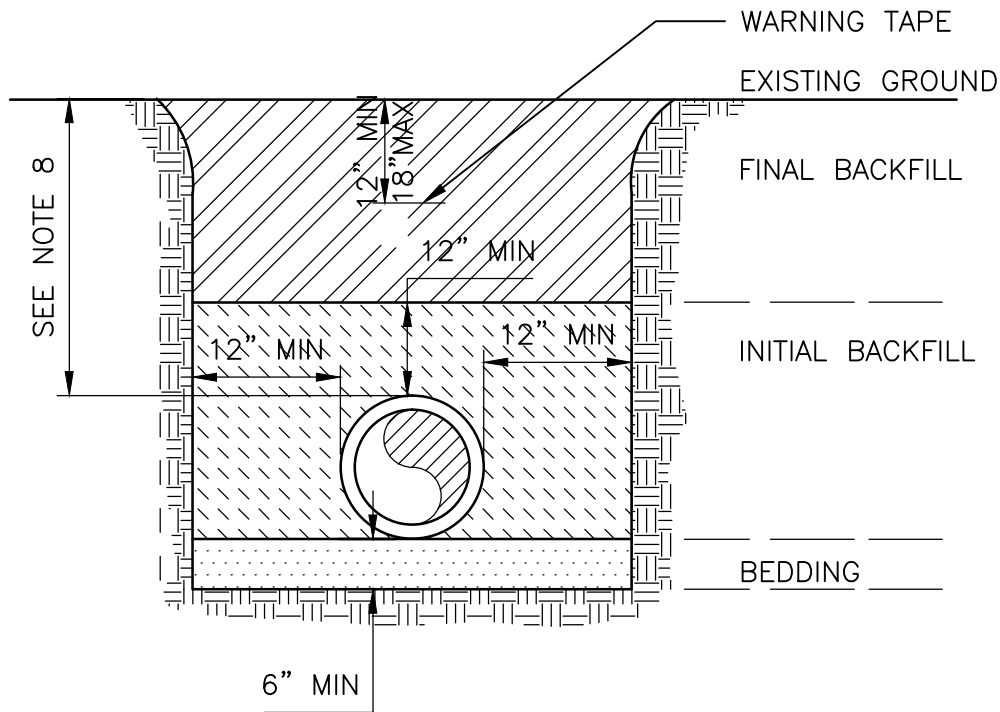

**NOTES:**

1. BEDDING MATERIAL SHALL BE HAND PLACED IN 6" LIFTS AND SHALL CONSIST OF IN-SITU GRANULAR MATERIAL OR APPROVAL MATERIAL. UNSUITABLE IN-SITU MATERIALS SUCH AS MUCK, DEBRIS AND ROCK SHALL BE REMOVED.
2. THE PIPE SHALL BE FULLY SUPPORTED FOR ITS ENTIRE LENGTH WITH APPROPRIATE COMPACTION UNDER THE PIPE HAUNCHES.
3. THE PIPE SHALL BE PLACED IN A DRY TRENCH.
4. BACKFILL SHALL BE DONE WITH APPROVED MATERIAL, CLEAN AND FREE OF ROCKS, MUCK AND OTHER DELETERIOUS MATTER AND COMPACTED BENEATH THE HAUNCHES OF THE PIPE USING MECHANICAL TAMPERS TO 100% MAXIMUM DENSITY AS DETERMINED BY AASHTO T-99.
5. BACKFILL TO BE COMPACTED ALONG THE SIDES OF THE PIPE AND TO A POINT ONE FOOT ABOVE THE TOP OF THE PIPE TO 100% MAXIMUM DENSITY AS DETERMINED BY AASHTO T-99.
6.
  - A. WHERE PAVEMENT IS TO BE CONSTRUCTED OVER THE PIPE, THE REMAINING BACKFILL SHALL BE COMPACTED IN 6 INCH LAYERS AND COMPACTED TO 98% MAXIMUM DENSITY AS DETERMINED BY AASHTO T-180
  - B. WHERE "NO" PAVEMENT IS TO BE CONSTRUCTED OVER THE PIPE, THE REMAINING FILL SHALL BE COMPACTED IN 6 INCH LAYERS TO A DENSITY 95% MAXIMUM DENSITY AS DETERMINED BY AASHTO T-180.
7. CONTRACTOR SHALL COMPLY WITH ALL STATE AND LOCAL TRENCH SAFETY REGULATIONS
8. MINIMUM COVER: UP TO 8" PIPE IS 30" COVER; 10" TO 12" PIPE IS 36" COVER; 14" AND LARGER PIPE IS 48" COVER.

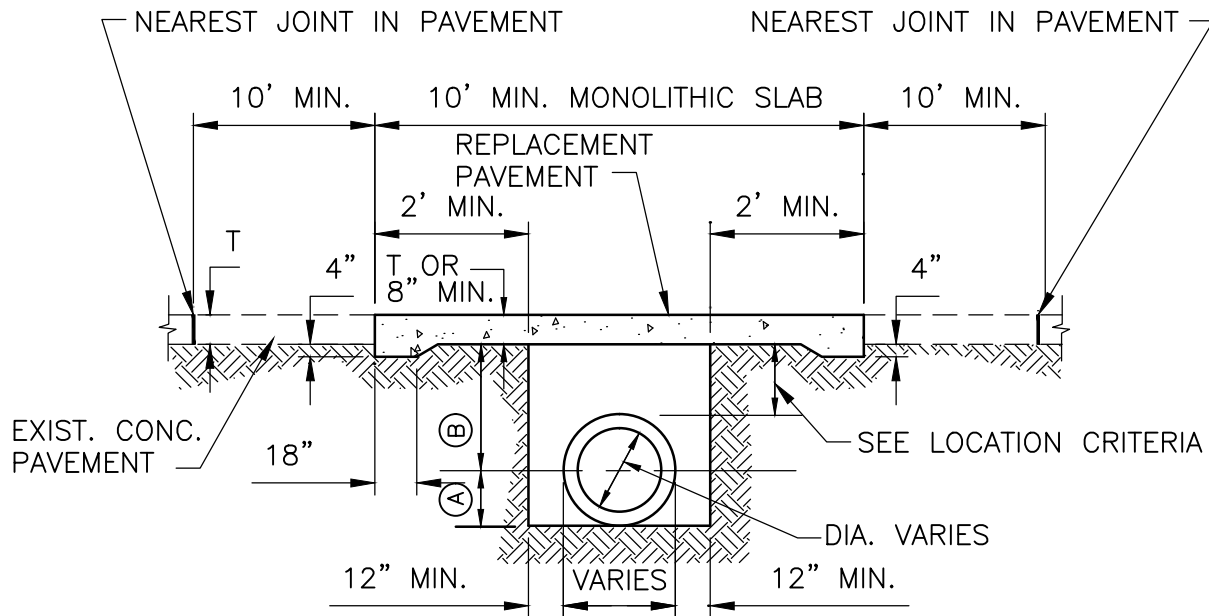

REPLACEMENT OF CONCRETE PAVEMENT  
FOR PERMITTED PAVEMENT CUT

DENSITY PROCEDURES:

THE BACKFILL FOR A AND B SHALL BE PLACED IN 6" LAYERS (COMPACTED THICKNESS) AND SHALL BE COMPACTED TO 100% OF MAXIMUM DENSITY AS DETERMINED BY AASHTO T-99 METHOD "C".

- Ⓐ THE PERMITTEE SHALL PROVIDE ADEQUATE COMPACTED FILL BENEATH THE A HAUNCHES OF THE PIPE, USING MECHANICAL TAMPS SUITABLE FOR THIS PURPOSE. THIS COMPACTION APPLIES TO THE MATERIAL PLACED BENEATH THE HAUNCHES OF THE PIPE AND ABOVE ANY BEDDING REQUIRED.
- Ⓑ THE PERMITTEE SHALL OBTAIN A WELL COMPACTED BED AND FILL ALONG THE B SIDES OF THE PIPE AND TO A POINT INDICATING THE BOTTOM OF REPLACEMENT PAVEMENT.

GENERAL NOTES:

1. 3000 P.S.I. CONCRETE, BY USE OF HIGH EARLY STRENGTH CEMENT, TO BE USED FOR REPLACEMENT, OR OTHER APPROVED HIGH STRENGTH, FAST SET MATERIALS. CONCRETE PAVEMENT JOINTS SHALL BE MECHANICALLY SAWED TO CONFORM WITH ADJOINING SLABS.
2. WITH ADJOINING SLABS.
3. BACKFILL MATERIAL SHALL BE EITHER OF THE SAME TYPE AND COMPOSITION AS THE MATERIAL REMOVED, OR OF EQUAL OR GREATER STRUCTURAL ADEQUACY. MATERIALS CONTAMINATED WITH DELETERIOUS SUBSTANCES DURING EXCAVATION SHALL NOT BE USED.



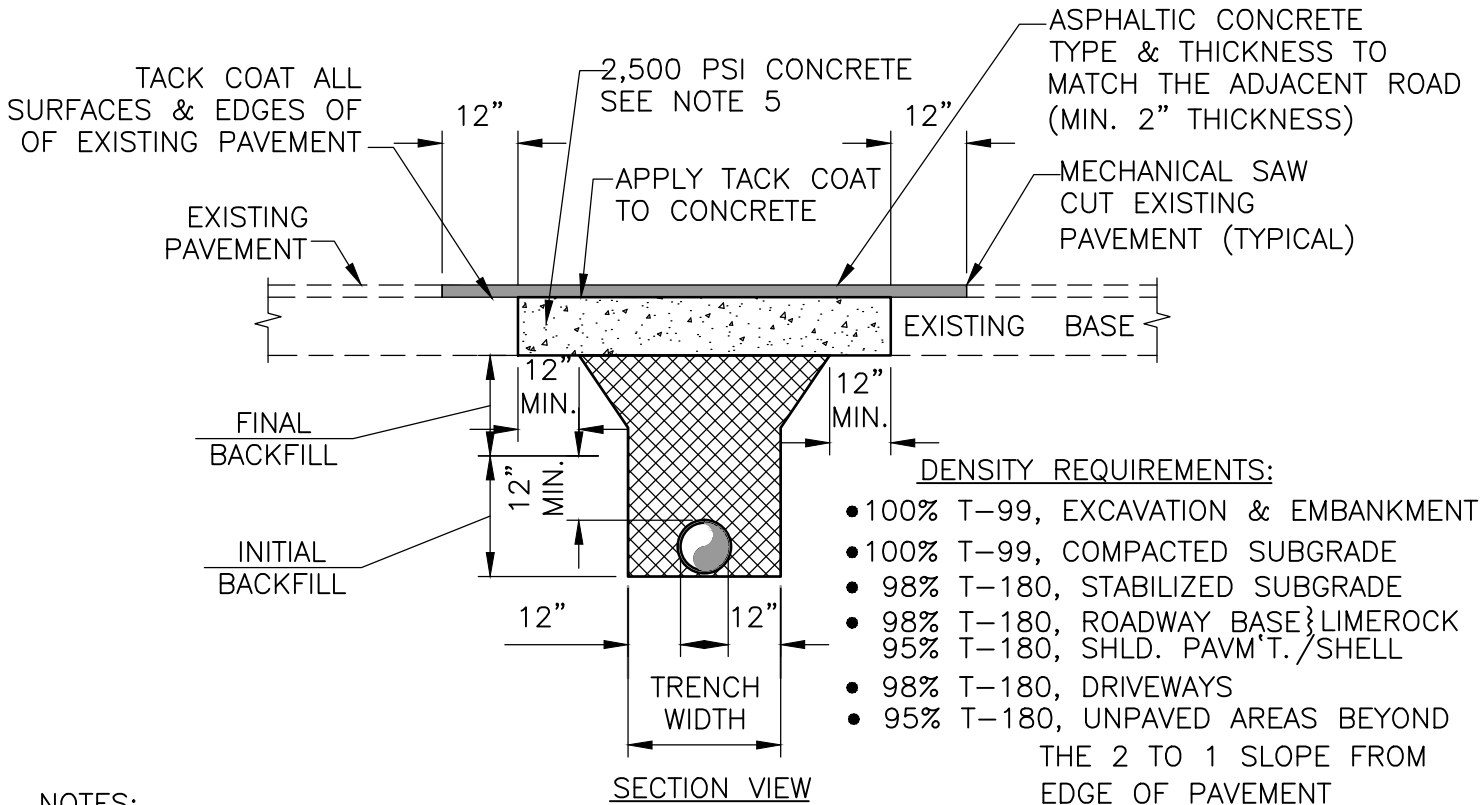
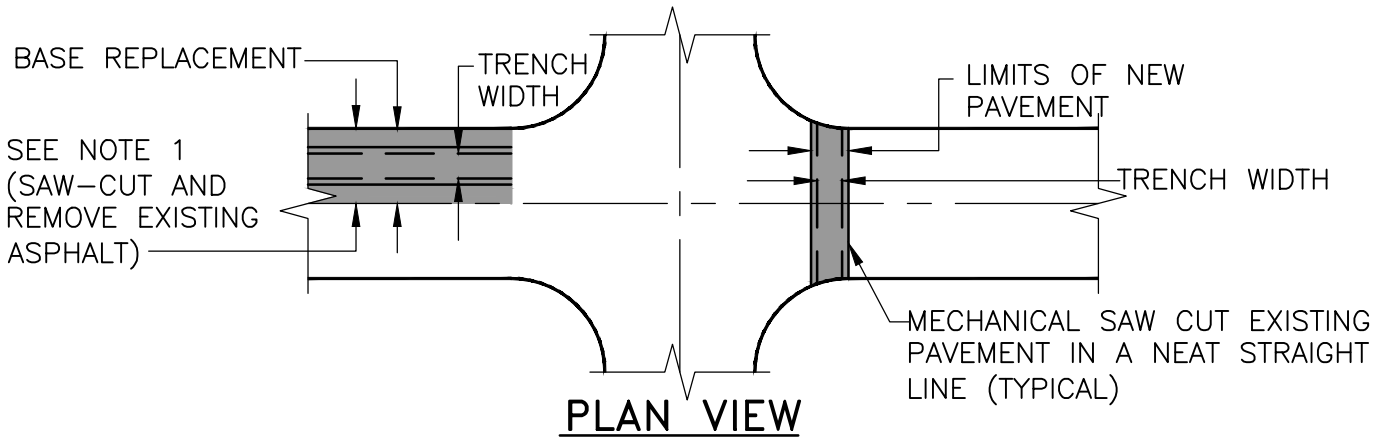

**NOTES:**

1. PAVEMENT RESTORATIONS FOR LONGITUDINAL CUTS IN ALL STREETS SHALL BE FULL LANE WIDTH, WITH FULL LANE WIDTH RESURFACING FOR EACH LANE WITHIN THE LIMITS OF THE CUT.
2. WHEN AN ARTERIAL OR MAJOR COLLECTOR STREET IS OPEN CUT WITHIN THE LIMITS OF THE ROADWAY INTERSECTION, THE ENTIRE INTERSECTION SHALL BE OVERLAID WITH ASPHALTIC CONCRETE.
3. WHEN STREETS OTHER THAN ARTERIALS OR MAJOR COLLECTORS ARE OPEN CUT MORE THAN TWO TIMES AT THE INTERSECTION, THE ENTIRE INTERSECTION SHALL BE OVERLAID WITH ASPHALTIC CONCRETE. TWO OPEN CUTS OR LESS AT THE INTERSECTION WILL REQUIRE OVERLAYING WITH ASPHALT ONLY IN THE OPEN CUT AREA.
4. THE CONTRACTOR SHALL BE REQUIRED TO DOCUMENT ALL PAVEMENT MARKINGS PRIOR TO OVERLAY. THE CONTRACTOR SHALL THEN PLACE NEW PAVEMENT MARKINGS AT THE SAME LOCATIONS. PAVEMENT MARKINGS SHALL BE IN ACCORDANCE TO F.D.O.T. SECTION 711.
5. 2500 PSI CONCRETE THICKNESS SHALL MATCH EXISTING BASE THICKNESS (6" MIN.)



ST. LUCIE COUNTY  
WATER & WASTEWATER  
CONSTRUCTION  
STANDARDS

UTILITY ROAD CUT  
PAVEMENT RESTORATION

DATE APPROVED: DECEMBER 2015

DRAWING NUMBER:

G-8

MIN. LENGTH OF PIPE (FEET) TO BE RESTRAINED  
 (SOURCES: EBAA IRON RESTRAINT LENGTH CALCULATION PROGRAM FOR PVC PIPE, V7.0.1)

FITTING TYPE		PIPE SIZE							
		4"	6"	8"	10"	12"	16"	20"	24"
90° HORIZ. BEND		21	28	37	37	43	55	66	76
45° HORIZ. BEND		9	12	16	16	18	23	28	32
22.5° HORIZ. BEND		5	6	8	8	9	11	13	15
11.25° HORIZ. BEND		2	3	4	4	5	6	7	8
45° VERT. OFFSET	UPPER BEND	19	27	35	35	41	53	64	74
	LOWER BEND	6	8	10	12	14	18	22	25
22.5° VERT. OFFSET	UPPER BEND	9	13	17	17	20	26	31	36
	LOWER BEND	3	4	5	6	7	9	11	12
11.25° VERT. OFFSET	UPPER BEND	5	7	9	9	10	13	16	18
	LOWER BEND	2	2	3	3	4	5	6	6
DEAD END/INLINE VALVE		45	63	83	84	99	127	153	179
TEE (BRANCH RESTRAINT)	4"X ∅	27	—	—	—	—	—	—	—
	6"X ∅	18	45	—	—	—	—	—	—
	8"X ∅	9	38	64	—	—	—	—	—
	10"X ∅	1	32	59	65	—	—	—	—
	12"X ∅	1	25	53	61	79	—	—	—
	16"X ∅	1	9	42	52	72	107	—	—
	20"X ∅	1	1	29	42	64	101	133	—
	24"X ∅	1	1	15	32	55	95	128	158
REDUCER (LARGER PIPE RESTRAINT)	6"X ∅	33	—	—	—	—	—	—	—
	8"X ∅	60	35	—	—	—	—	—	—
	10"X ∅	81	61	33	—	—	—	—	—
	12"X ∅	101	85	62	29	—	—	—	—
	16"X ∅	138	126	109	75	54	—	—	—
	20"X ∅	171	161	148	113	96	54	—	—
	24"X ∅	201	194	183	146	132	98	54	—

NOTES:

- THE DATA IN THE ABOVE TABLE ARE BASED UPON THE FOLLOWING INSTALLATION CONDITIONS:  
 SOIL TYPE—SP TEST PRESSURE—150 PSI DEPTH OF BURY  
 TRENCH TYPE—3 SAFETY FACTOR— 1.5 (4"—8": 2.5'; 10" AND LARGER: 3')  
 MINIMUM PIPE LENGTH ALONG TEE RUN—5' VERTICAL OFFSET—3'
- THE RESTRAINED PIPE LENGTHS APPLY TO DUCTILE IRON AND PVC PIPE.
- ALL JOINTS BETWEEN UPPER AND LOWER BENDS SHALL BE RESTRAINED.
- RESTRAINED PIPE LENGTHS APPLY TO PIPE ON BOTH SIDES OF VALVES AND FITTINGS.
- ALL CONNECTIONS OF HDPE PIPE TO PUSH—ON—JOINT PIPE (EG. PVC, DIP, ETC.) SHALL BE RESTRAINED AS DEAD END



ST. LUCIE COUNTY  
 WATER & WASTEWATER  
 CONSTRUCTION  
 STANDARDS

RESTRAINED JOINT  
 SCHEDULE

DATE APPROVED: DECEMBER 2015

DRAWING NUMBER:

G-9

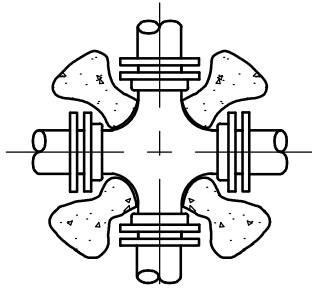

CROSS

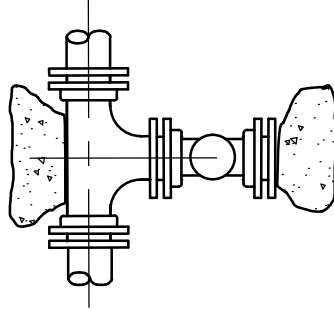

TEE W/ GATE VALVE

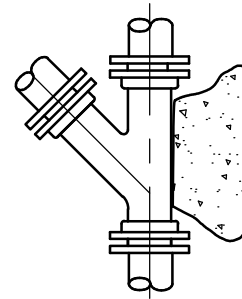

WYE WITH PLUG

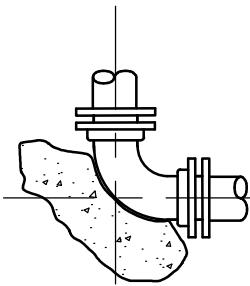

ELBOW

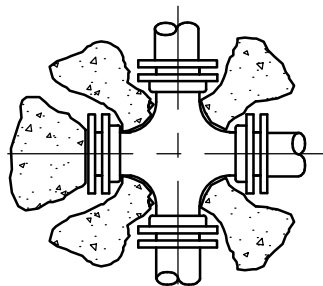

CROSS WITH PLUG

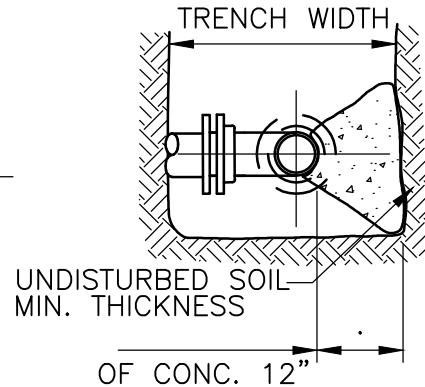

TYPICAL SECTION

PIPE DIA. ( ins. )	90° ELBOW	45° ELBOW	22 1/2° ELBOW	11 1/4° ELBOW	WYES / TEES	PLUGS
	CONC. (cu. ft.)	CONC. (cu. ft.)	CONC. (cu. ft.)	CONC. (cu. ft.)	CONC. (cu. ft.)	CONC. (cu. ft.)
2	0.5	0.5	0.5	0.5	0.5	0.5
3	1.0	1.0	1.0	1.0	1.0	1.0
4	1.2	1.0	1.0	1.0	1.0	1.0
6	2.6	1.4	1.0	1.0	1.0	1.0
8	4.6	2.5	1.3	1.0	3.3	3.3
10	7.3	3.9	2.0	1.0	5.9	5.9
12	10.0	5.7	2.9	1.5	7.7	7.7
14	14.2	7.7	3.9	2.0	10.0	10.0
16	18.5	10.0	5.6	2.6	13.4	13.4
18	23.4	12.7	6.5	3.3	16.6	16.6
20	28.8	15.6	8.0	4.7	20.0	20.0
24	41.7	22.3	10.2	5.9	29.0	29.0

NOTES:

1. MECHANICAL RESTRAINTS ONLY SHALL BE USED AT THE FITTINGS AND VALVES. THRUST BLOCKS SHALL ONLY BE USED IN RARE CASES WHEN MECHANICAL RESTRAINTS ARE NOT PRACTICAL WITH APPROVAL FROM THE DISTRICT.
2. CALCULATIONS BASED ON 150 P.S.I. PRESSURE AND 2000 P.S.F. SOIL BEARING VALUES.
3. THRUST BLOCKS SHALL BE FORMED AND POURED AGAINST UNDISTURBED SOIL. KEEP "T" BOLTS CLEAR OF CONCRETE, WRAPPED IN VISQUEEN FOR FUTURE ACCESS.
4. BEFORE POURING, PLUGS SHALL BE WRAPPED IN VISQUEEN AND A BOARD PLACED IN FRONT.
5. CONCRETE SHALL BE 2500 P.S.I. MIN.

## THRUST BLOCK BEARING AREA REQUIREMENTS (S.F.)

PIPE DIA.	FIRE HYDRANT, TEE DEAD ENDS AND VALVES (EACH SIDE)	90° BEND	45° BEND	22 1/2° BEND
4"	1.2	1.8	1.0	0.5
6"	2.6	3.8	2.0	1.0
8"	4.4	6.3	3.4	1.7
10"	8.1	11.4	6.2	3.1
12"	11.5	16.2	8.8	4.5
16"	20.2	28.5	15.4	7.8

## CUBIC YARDS OF CONCRETE ANCHOR FOR VERTICAL BENDS

PIPE DIA.	45° BEND	22 1/2° BEND	11 1/4° BEND
4"-6"	0.7	0.4	0.2
8"-10"	1.1	0.6	0.3
12"	2.4	1.3	0.7
16"	4.2	2.3	1.2

### NOTES:

1. MECHANICAL RESTRAINTS ONLY SHALL BE USED AT THE FITTINGS AND VALVES. THRUST BLOCKS SHALL ONLY BE USED IN RARE CASES WHEN MECHANICAL RESTRAINTS ARE NOT PRACTICAL WITH APPROVAL FROM THE DISTRICT.
2. REQUIRED BEARING AREA IS GIVEN ON PLAN OR SHALL BE DETERMINED FROM TABLE.
3. WHERE PIPE CHANGES DIAMETER TO FITTING, DETERMINE BEARING AREA BASED UPON THE LARGEST PIPE DIAMETER.
4. THE MINIMUM ALLOWABLE BEARING AREA SHALL BE ONE (1) SQUARE FOOT REGARDLESS OF ANY APPROVED REACTION CALCULATIONS.
5. BELOW THE GROUND WATER TABLE THE QUANTITY OF CONCRETE FOR ANCHORS SHALL BE 1.75 TIMES THAT GIVEN IN TABLE.
6. #5 REBAR, 2 REQUIRED, SHALL BE INSTALLED AROUND PIPE IN CONCRETE. ANCHOR FOR VERTICAL BENDS. SEE DETAIL G-5 (TYP).
7. THE ENGINEER OF RECORD SHALL CALCULATE THE SIZE OF THE THRUST BLOCK/ANCHOR REQUIRED AS WELL AS ANY INSTALLATION NOT COVERED BY THE ABOVE.

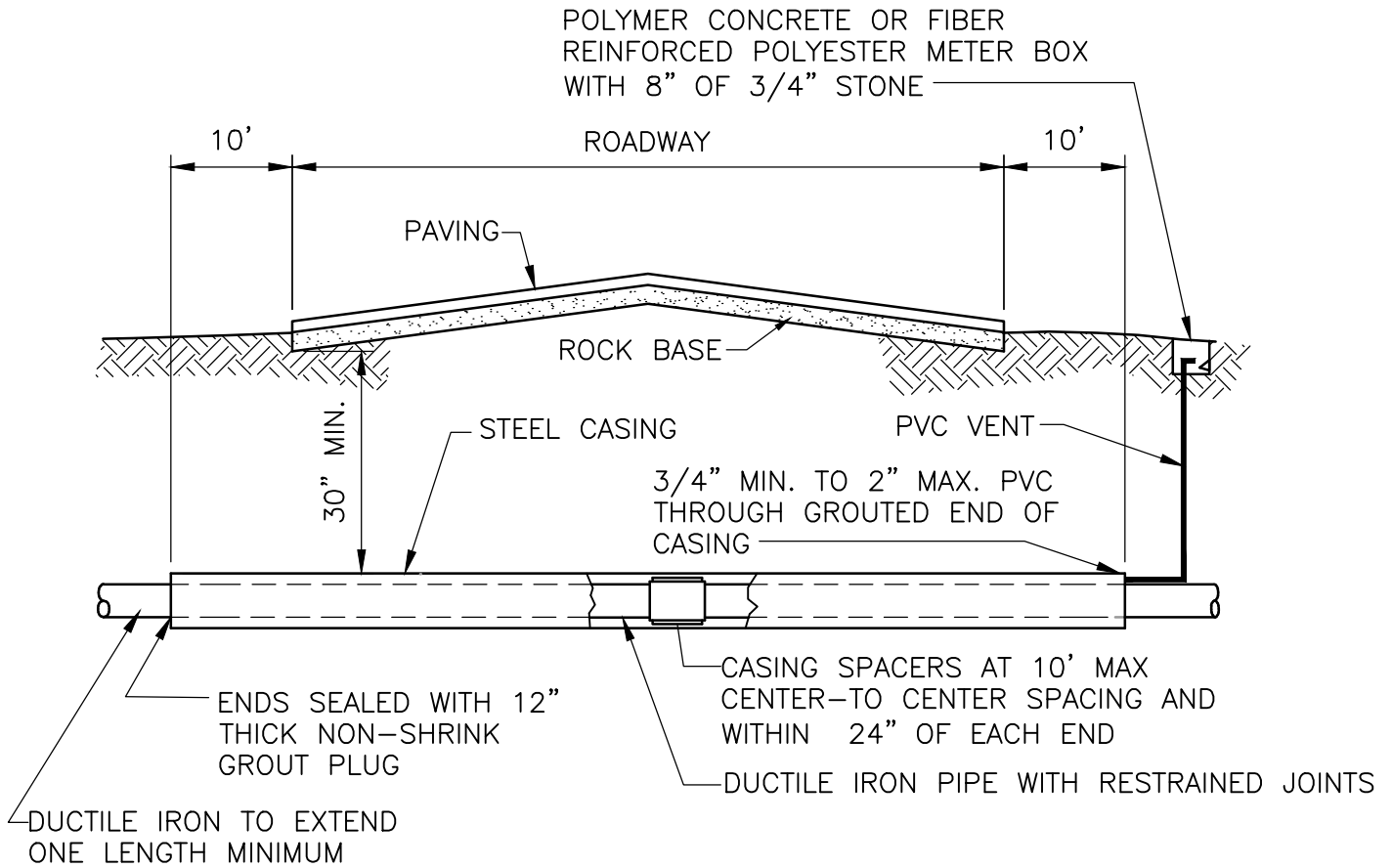

CARRIER PIPE SIZE	MINIMUM STEEL CASING	MINIMUM WALL THICKNESS
4"	12"	.250
6"	16"	.250
8"	18"	.3125
10"	20"	.3125
12"	24"	.375
16"	30"	.500
18"	30"	.500
20"	36"	.5625
24"	36"	.5625
30"	42"	.5625
36"	48"	.5625

NOTES:

1. CASING SPACER RUNNER HEIGHTS SHALL NOT INTERFERE WITH PIPE JOINT RESTRAINTS.
2. RETAINER GLANDS ARE REQUIRED SO THE CASING SIZE SHALL BE ADJUSTED ACCORDINGLY.
3. LOCATOR WIRE FOR ALL BORE & JACKING AND HORIZONTAL DIRECTIONAL DRILLS SHALL HAVE 600 LB MIN BREAK LOAD AND BE SUITABLE FOR THE INSTALLATION. SEE THE TECHNICAL SPECIFICATIONS FOR ADDITIONAL REQUIREMENTS.



ALL VALVES SHALL HAVE CONTINUOUS TRACE WIRE INSTALLED UNDER A BOLT AS FOLLOWS: FIRST LOOSEN BOLT, THEN STRIP 3" MIN., WRAP ONCE AROUND BOLT, 1 TWIST, 2 WRAPS.

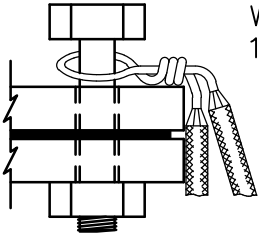

"DO NOT CUT WIRE"  
TIGHTEN BOLT AFTER WRAPPING TRACE WIRE AROUND THE BOLT.

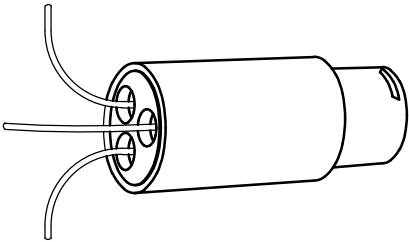

DETAIL OF THREE (3) WIRE SPLICE

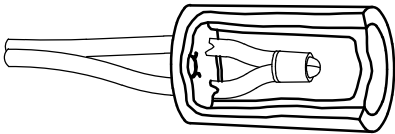

CUTAWAY DETAIL OF A TWO (2) WIRE SPLICE

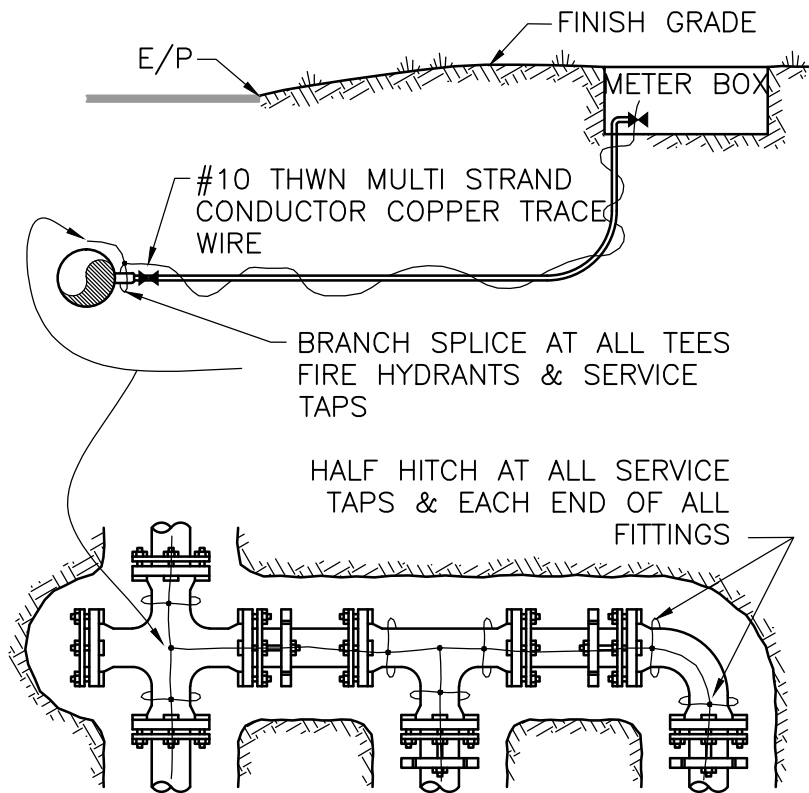
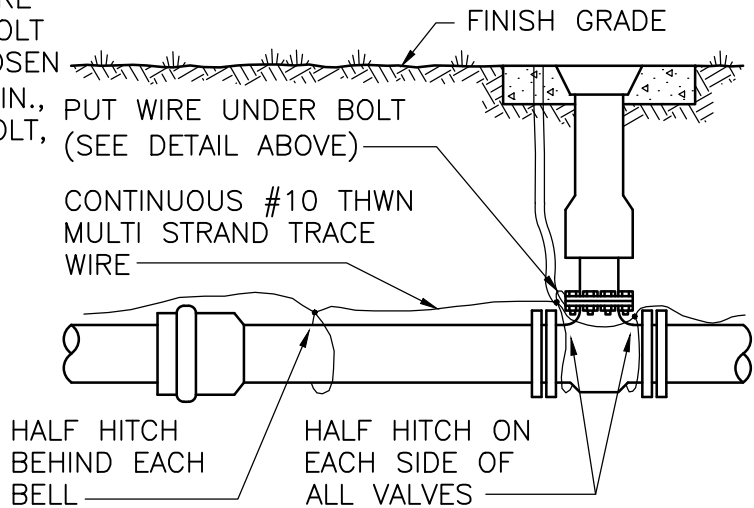

NOTES:

1. TRACE WIRE IS REQUIRED ON ALL PIPE AS NOTED BY DISTRICT AND THE ENGINEER, AND SHOWN IN STANDARD DETAILS.
2. INCLUDE ALL COST OF MATERIAL & LABOR IN PRICE OF PIPE.
3. CONTRACTOR IS RESPONSIBLE FOR CONTINUITY OF ALL TRACE WIRE TO TEST DURING START UP IN THE PRESENCE OF THE DISTRICT.

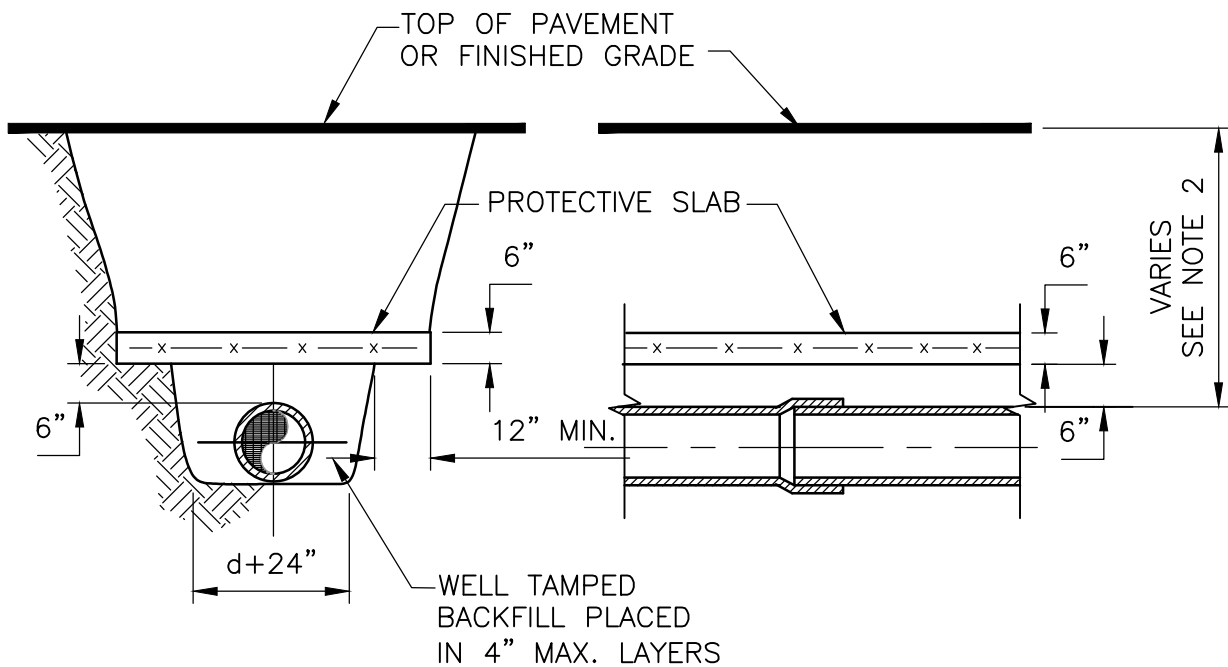

NOTES:

1. CONCRETE PROTECTIVE SLAB SHALL BE 2500 P.S.I. WITH 6"X6"-10/10 W.W. MESH CENTERED IN THE SLAB AND 12" MIN. BEARING EACH SIDE OF TRENCH.
2. PROTECTIVE SLAB REQUIRED WHERE COVER FOR MAINS IS LESS THAN 30" AND LATERALS WHEN LESS THAN 24".

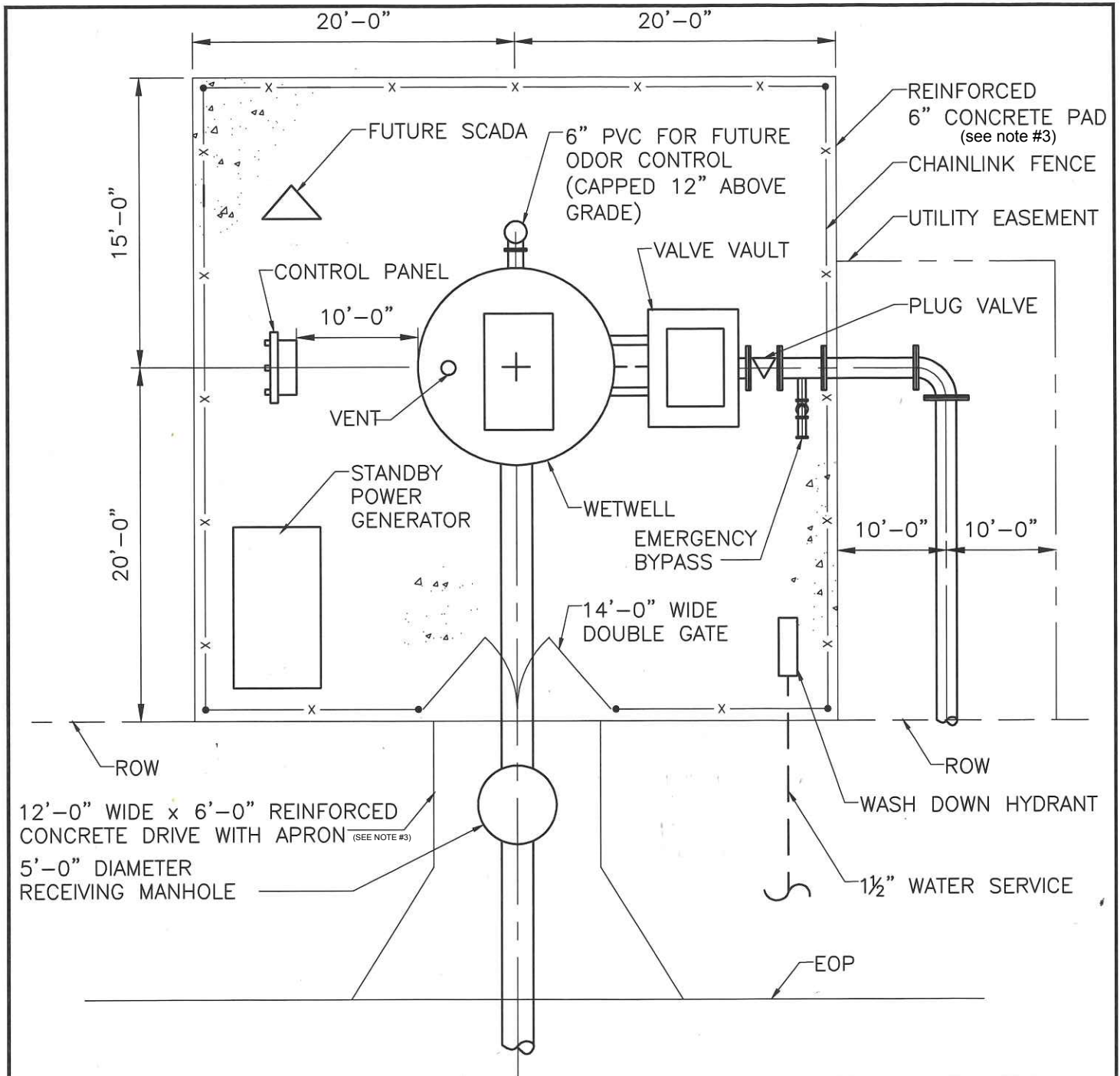

Notes:

1. APPLIES TO LIFT STATIONS SERVING 500 ERCS OR GREATER OR RECEIVING FLOW FROM ONE OR MORE LIF STATION.
2. ALTERNATE LIFT STATION LAYOUTS WILL BE CONSIDERED BY THE DISTRICT ON A CASE-BY CASE BASIS.
3. CONCRETE DRIVE WAY - MINIMUM 3,000 PSI WITH RE-INFORCE WIRE OR FIBER AND MINIMUM 6" THICKNESS.

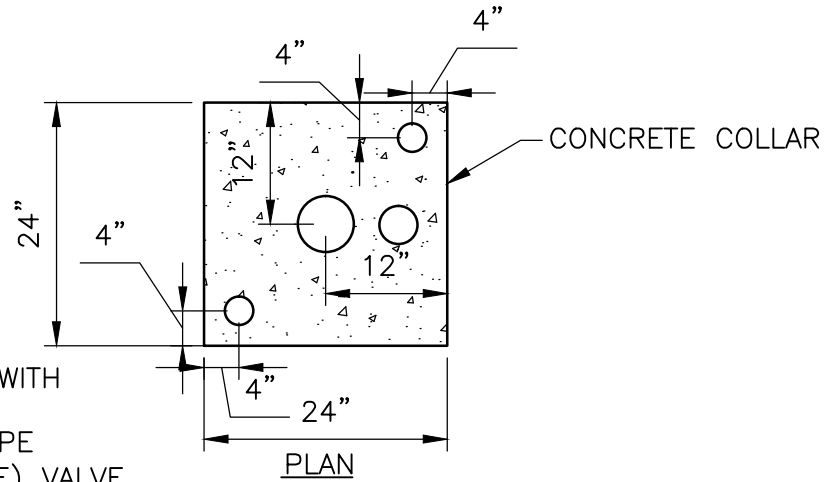

MOUNT BRONZE DISC WITH VALVE NOMENCLATURE INCLUDING SERVICE TYPE (WATER, SEWER, REUSE) VALVE TYPE (CV, GV, BV) AND DIRECTION AND NUMBER OF TURNS TO OPEN

POUR CONCRETE TO GRADE  
TOP OF PAVEMENT

HEAVY DUTY C.I. COVER MARKED "WATER", "SEWER" OR "REUSE" AND SHALL HAVE BOLT DOWN COVER IN TRAFFIC AREAS

(2) #3 CLOSED TIES @ 5" O.C.  
2" FROM TOP

HEAVY DUTY C.I. ADJUSTABLE VALVE BOX (INSIDE SCREW TYPE)  
SQUARE NUT

VALVE BOX SHALL REST ON STONE, NOT ON VALVE

COMPACTED FDOT NO. 89 STONE (6" MIN DEPTH)

APPROVED MECHANICAL JOINT VALVE

CONTINUOUS 10 GAGE STRANDED COPPER WIRE TERMINATING IN CURB STOP BOX IN PAD

2" PLUG STYLE CURB STOP BOX

ELEVATION

NOTES:

1. WHEN TOP OF OPERATING NUT IS DEEPER THAN 42", A STAINLESS STEEL EXTENSION WILL BE REQUIRED TO BRING OPERATING NUT 12" BELOW FINISHED GRADE. A STAINLESS STEEL CENTERING PLATE, WELDED TO THE EXTENSION, IS ALSO REQUIRED.
2. COVER SHALL BE PAINTED FEDERAL SAFETY BLUE FOR WATER MAINS, GREEN FOR SEWER MAINS AND PURPLE FOR RECLAIMED MAINS.
3. C900 P.V.C. OR D.I.P. RISER PIPE SHALL BE ADDED TO EXTEND THE VALVE BOX AS REQUIRED.
4. REFLECTIVE PAVEMENT MARKERS (RPM) SHALL BE 6" FROM THE EDGE OF PAVEMENT AS PER DOT INSTALLATION SPECIFICATIONS. WATER RPM'S "BLUE", SEWER RPM'S "GREEN" AND RECLAIMED WATER RPM'S "PURPLE".

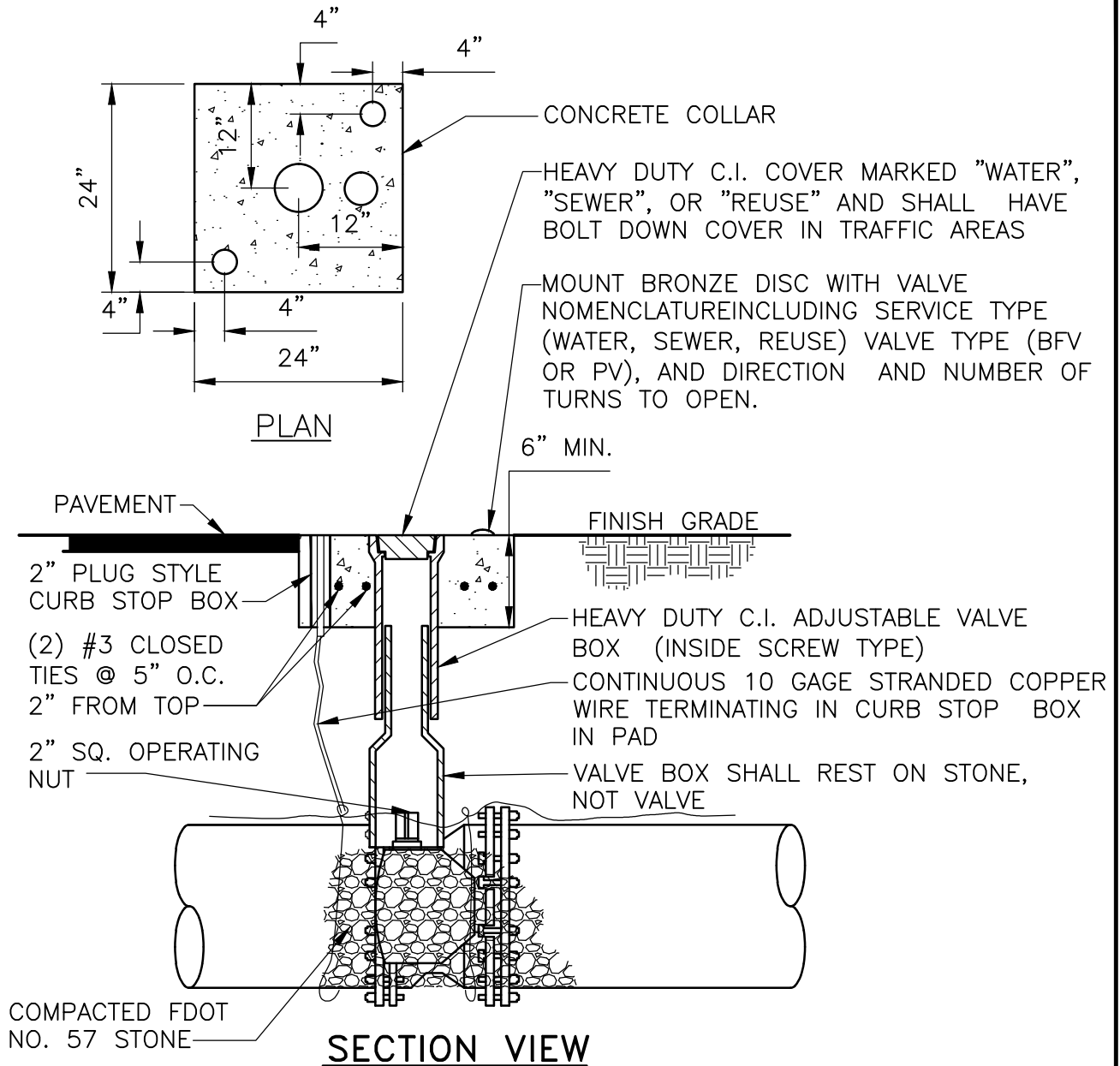

**NOTES:**

1. WHEN TOP OF OPERATING NUT IS DEEPER THAN 42", A STAINLESS STEEL EXTENSION WILL BE REQUIRED TO BRING OPERATING NUT 12" BELOW FINISHED GRADE. A STAINLESS STEEL CENTERING PLATE, WELDED TO THE EXTENSION, IS ALSO REQUIRED.
2. VALVE SHALL BE INSTALLED SO THAT OPERATING NUT AND VALVE BOX ARE LOCATED ON THE RIGHT-OF-WAY SIDE OF THE MAIN.
3. C900 P.V.C. OR D.I.P. RISER PIPE SHALL BE ADDED TO EXTEND THE VALVE BOX AS REQUIRED.
4. REFLECTIVE PAVEMENT MARKERS (RPM) SHALL BE 6" FROM THE EDGE OF PAVEMENT AS PER DOT INSTALLATION SPECIFICATIONS. WATER RPM'S SHALL BE "BLUE", SEWER RPM'S SHALL BE "GREEN", AND RECLAIMED RPM'S SHALL BE "PURPLE".

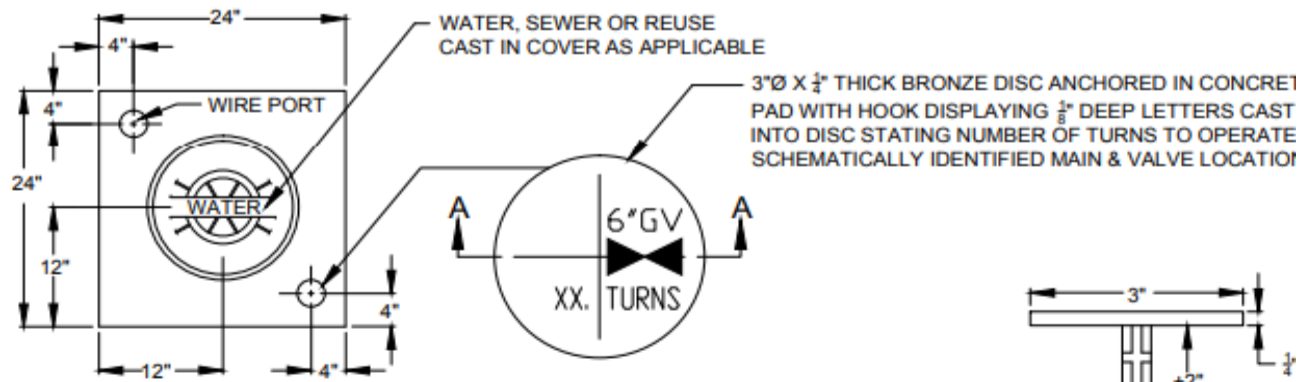

**CONCRETE VALVE COLLAR**

**SECTION A-A**

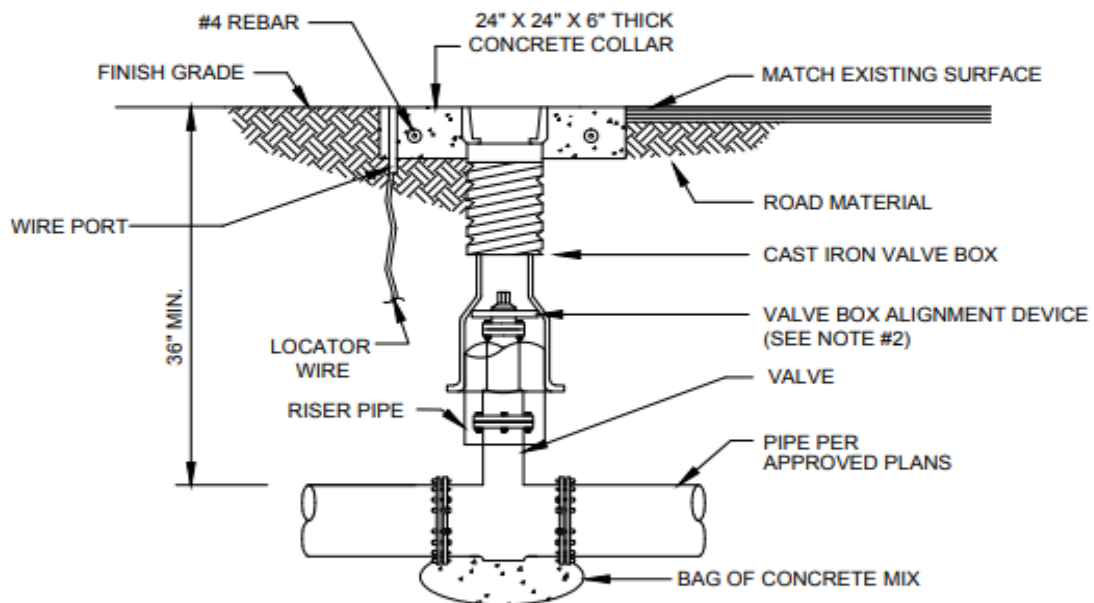

**NOTES:**

1. WHEN TOP OF OPERATING NUT IS DEEPER THAN 30", A HIGH STRENGTH STEEL EXTENSION WILL BE REQUIRED TO BRING OPERATING NUT 24"-30" BELOW FINISHED GRADE. A STEEL CENTERING PLATE, WELDED TO THE EXTENSION, IS ALSO REQUIRED.
2. A VALVE BOX ALIGNMENT DEVICE SHALL BE PROVIDED TO ELIMINATE SHIFTING OF THE VALVE BOX AGAINST THE OPERATING NUT.
3. BOLT DOWN COVER SHALL BE USED IN ALL AREAS.
4. C900 P.V.C. RISER PIPE SHALL BE ADDED TO EXTEND THE VALVE BOX IF NEEDED.
5. RPM'S SHALL NOT BE INSTALLED IN CROSSWALKS OR PEDESTRIAN WALKWAYS.
6. THE TOP SIDE OF THE VALVE BOX COVER AND THE INSIDE OF TOP SECTION OF THE VALVE BOX SHALL BE PAINTED BLUE FOR WATER MAINS, GREEN FOR SEWER MAINS AND PURPLE FOR RECLAIMED WATER MAINS.



ST. LUCIE COUNTY  
WATER & WASTEWATER  
CONSTRUCTION  
STANDARDS

TYPICAL VALVE BOX AND COLLAR

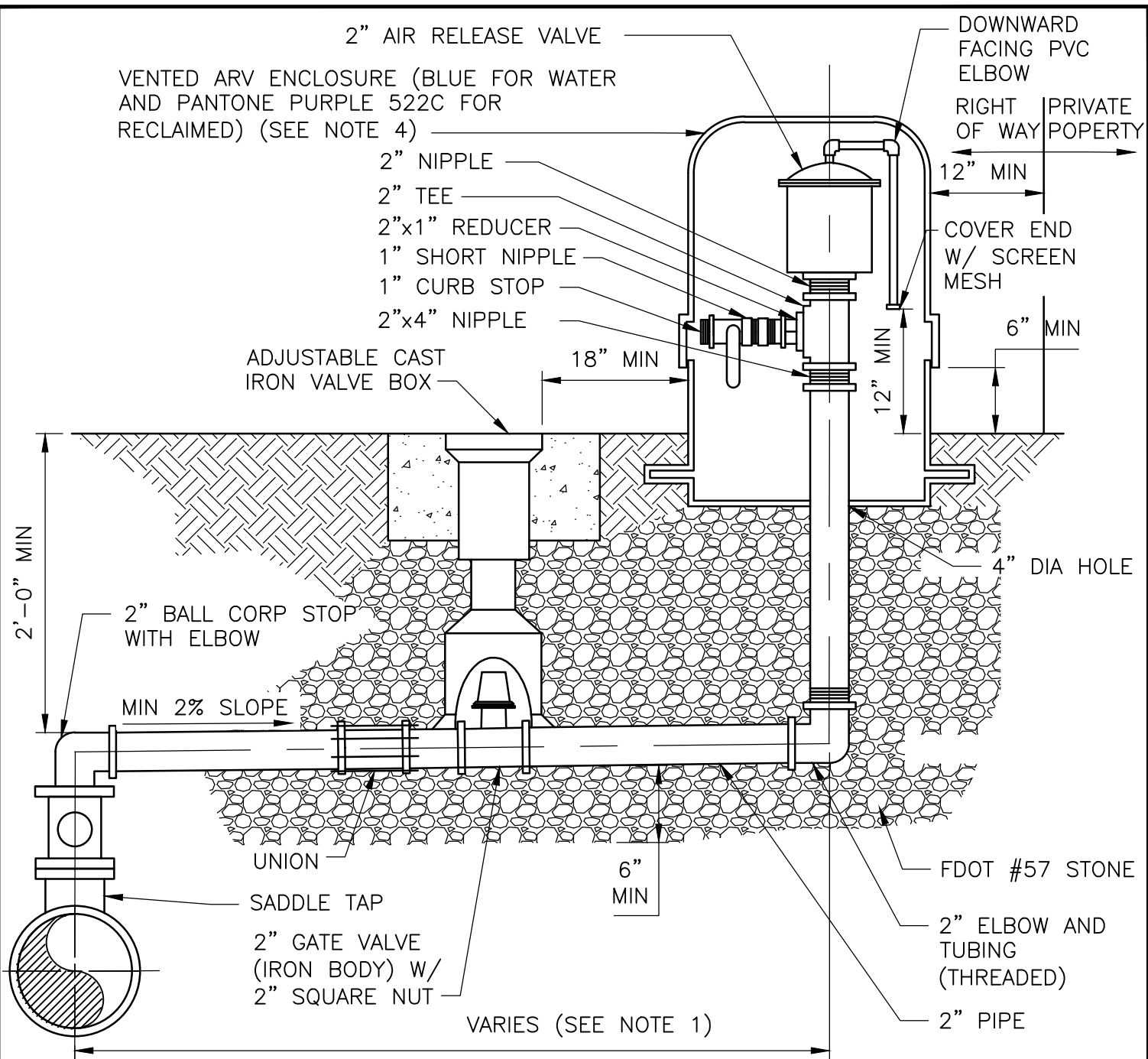

**NOTES:**

1. OFFSET DISTANCE TO BE FIELD DETERMINED AND AS CLOSE TO THE RIGHT OF WAY AS POSSIBLE AND CLEAR OF PEDESTRIAN WALKWAYS. IF PIPE AT RIGHT OF WAY LINE, NO OFFSET REQUIRED.
2. ABOVE DETAIL APPLIES TO A 2" ARV. FOR LARGER ARV'S, PIPE DIAMETER SHALL BE EQUAL TO THE SIZE OF THE ARV.
3. ALL PIPING, VALVES, AND APPURTENANCES TO BE BRASS OR 316 SS EXCEPT WHERE SPECIFIED OTHERWISE.
4. THE ENCLOSURE VENT MUST BE CAPABLE OF ALLOWING AT LEAST THE SAME AMOUNT OF AIRFLOW AS THE VALVE.



**ST. LUCIE COUNTY  
WATER & WASTEWATER  
CONSTRUCTION  
STANDARDS**

**AIR VALVE AND BOX  
(POTABLE / RECLAIMED)**

DATE APPROVED: DECEMBER 2015      DRAWING NUMBER: **G-18**

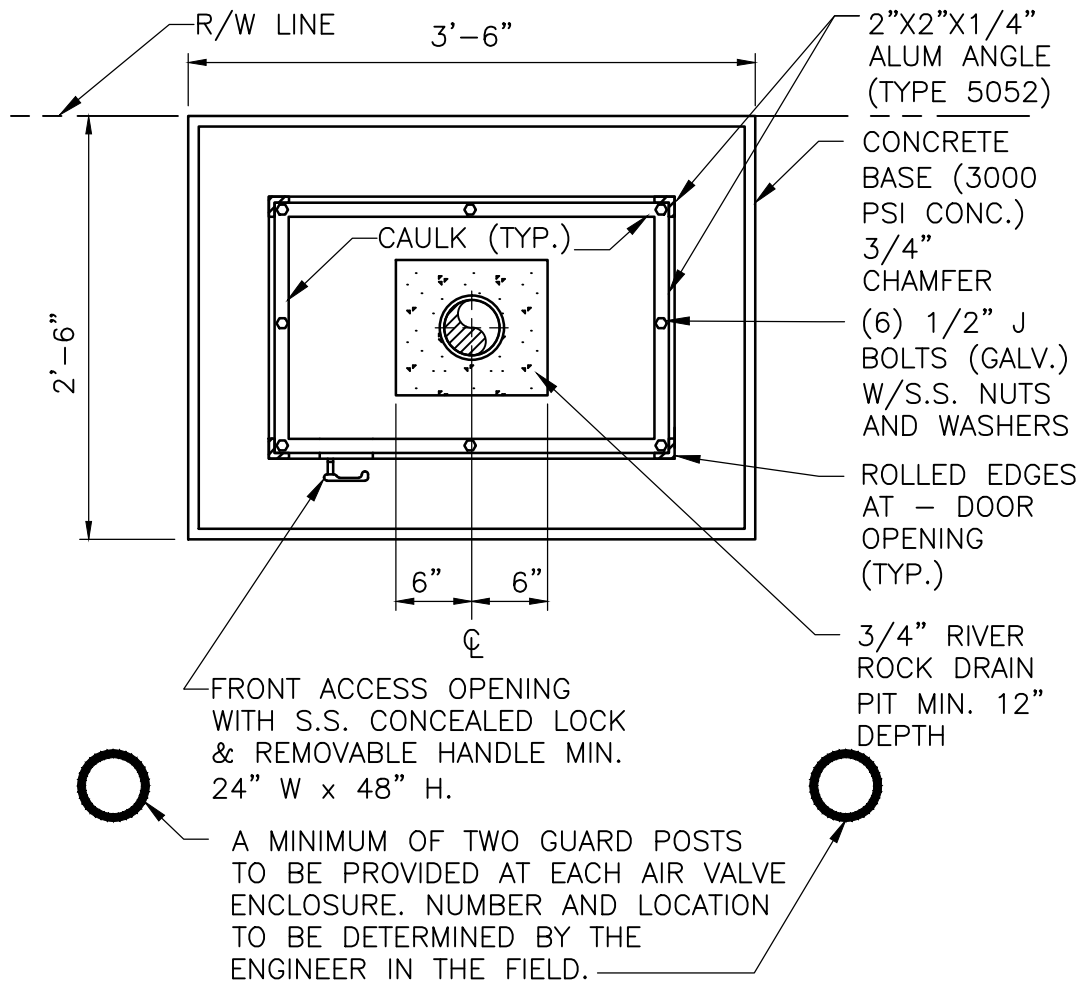

**NOTES:**

1. OFFSET DISTANCE TO BE FIELD DETERMINED AND AS CLOSE TO THE RIGHT OF WAY AS POSSIBLE AND CLEAR OF PEDESTRIAN WALKWAYS. IF PIPE AT RIGHT OF WAY LINE, NO OFFSET REQUIRED.
2. ABOVE DETAIL APPLIES TO A 2" ARV. FOR LARGER ARV'S, PIPE DIAMETER SHALL BE EQUAL TO THE SIZE OF THE ARV.
3. ALL ALUMINUM TO BE TYPE 5052.
4. ALL AIR RELEASE PIPING AND FITTINGS TO BE TYPE 316 SS. THREADED EXCEPT WHERE SHOWN OTHERWISE.
5. FLUSHING ATTACHMENTS NOT SHOWN FOR CLARITY.
6. THE HEIGHT OF THE CONCRETE BASE TO BE DETERMINED BY THE ENGINEER IN THE FIELD.



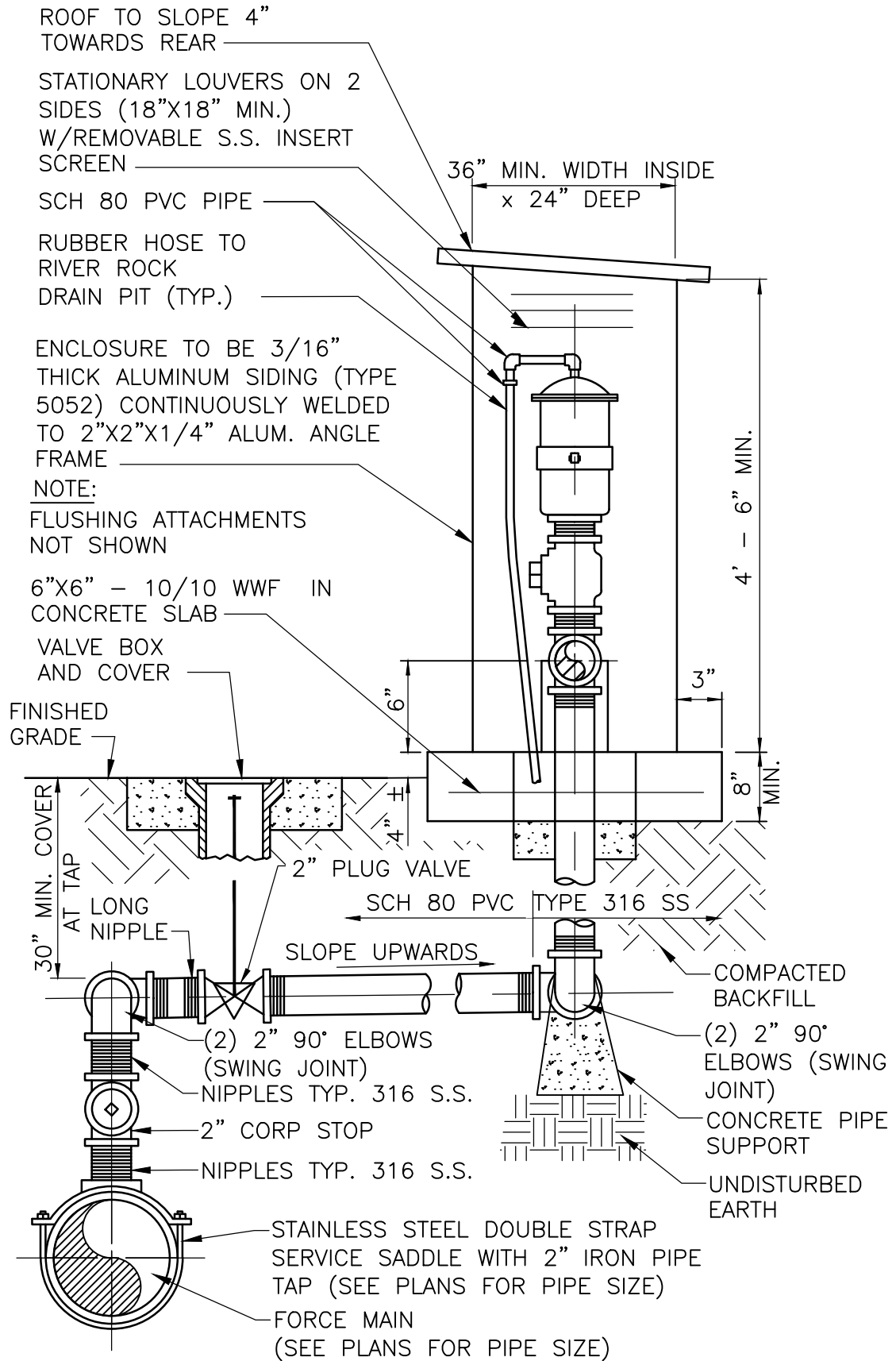

ROLLED EDGE  
AT DOOR  
OPENING (TYP.)

FRONT ACCESS  
OPENING WITH  
LOCK MIN. 24"  
WIDE X 48"  
HIGH

2" AIR RELEASE  
VALVE (SMALL  
ORIFICE) WITH  
FLUSHING  
ATTACHMENTS  
(TYP. FOR BOTH  
VALVES)

2" CROSS WITH  
REDUCING  
BUSHING 1"  
SHUT-OFF VALVE,  
PRESSURE GAUGE  
AND DIAPHRAGM  
ASSEMBLY

INSTALL FLUSH  
IN SIDEWALK  
AREA AND  
PROVIDE 1/2"  
EXP. JT. MAT'L  
AROUND BASE

FINISH  
GRADE

COMPACTED  
BACKFILL

TYPE 316 SS

36" MIN. WIDTH INSIDE  
x 24" DEEP

9" 9"

CONTINUOUS  
ALUM HINGE AT  
DOOR

REINFORCE DOOR  
FOR TRUE  
ALIGNMENT AND  
EASE OF  
OPERATION

2" AIR AND  
VACUUM VALVE  
(LARGE ORIFICE)

STAINLESS  
STEEL BOLTS  
(TYP.)

1/8"x2" PREFORMED  
SUPPORT STRAP  
BOLTED TO THE  
ENCLOSURE FRAME  
(ALUM)

2" TYPE 316 S.S.  
(TYP.)

2" PLUG VALVE  
(TYP.)

CONCRETE BASE  
ALUM PIPE STRAP  
BOLTED TO CONC.  
SUPPORT (S.S.  
ANCHORS)

1-NO.4 (TYP.)

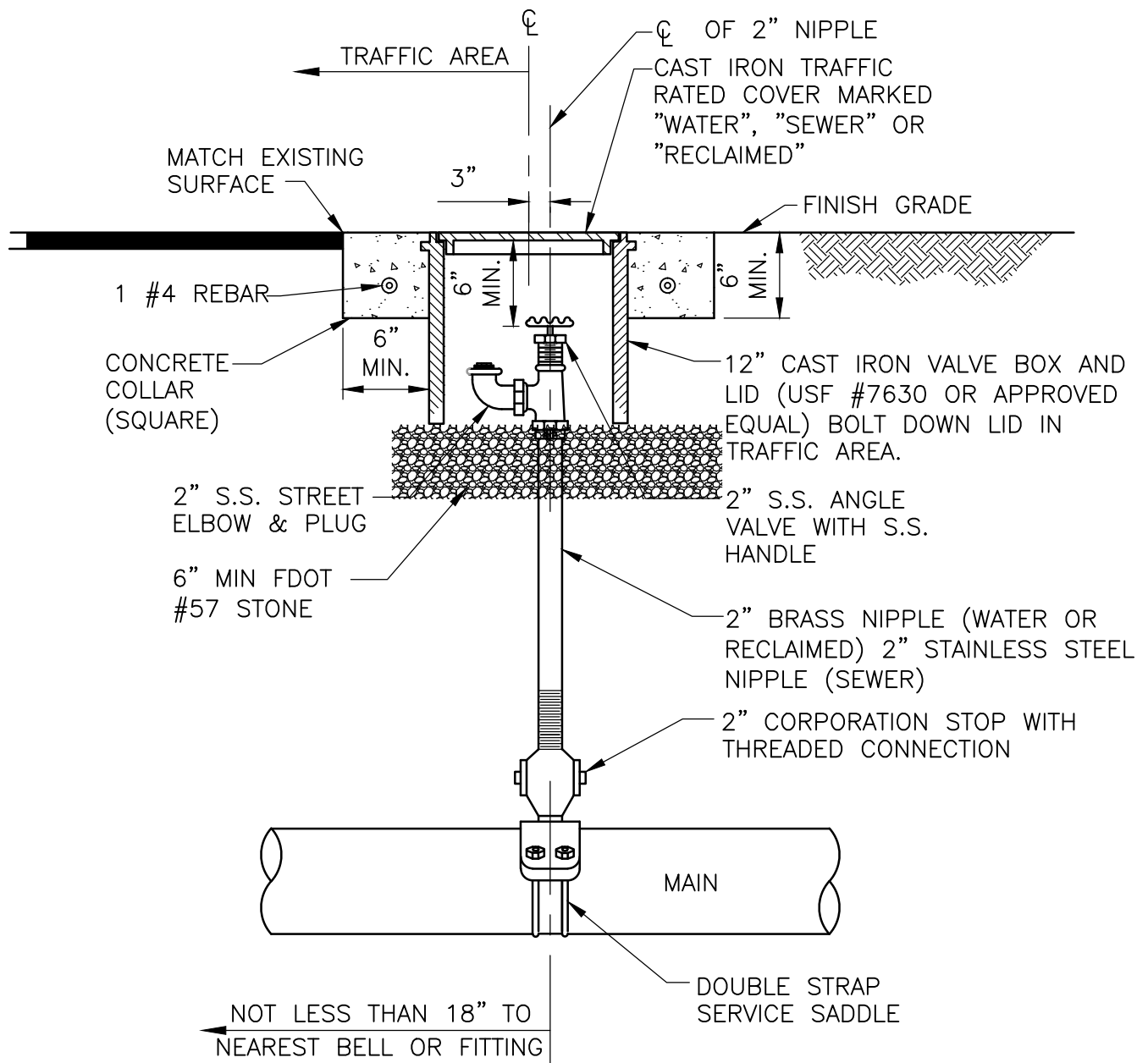

**NOTES:**

1. COVER SHALL BE PAINTED "BLUE" FOR WATER, "GREEN" FOR SEWER OR "PURPLE" FOR RECLAIMED.
2. MANUAL AIR RELEASE VALVE TO BE INSTALLED ONLY WHEN PRE-APPROVED BY DISTRICT.

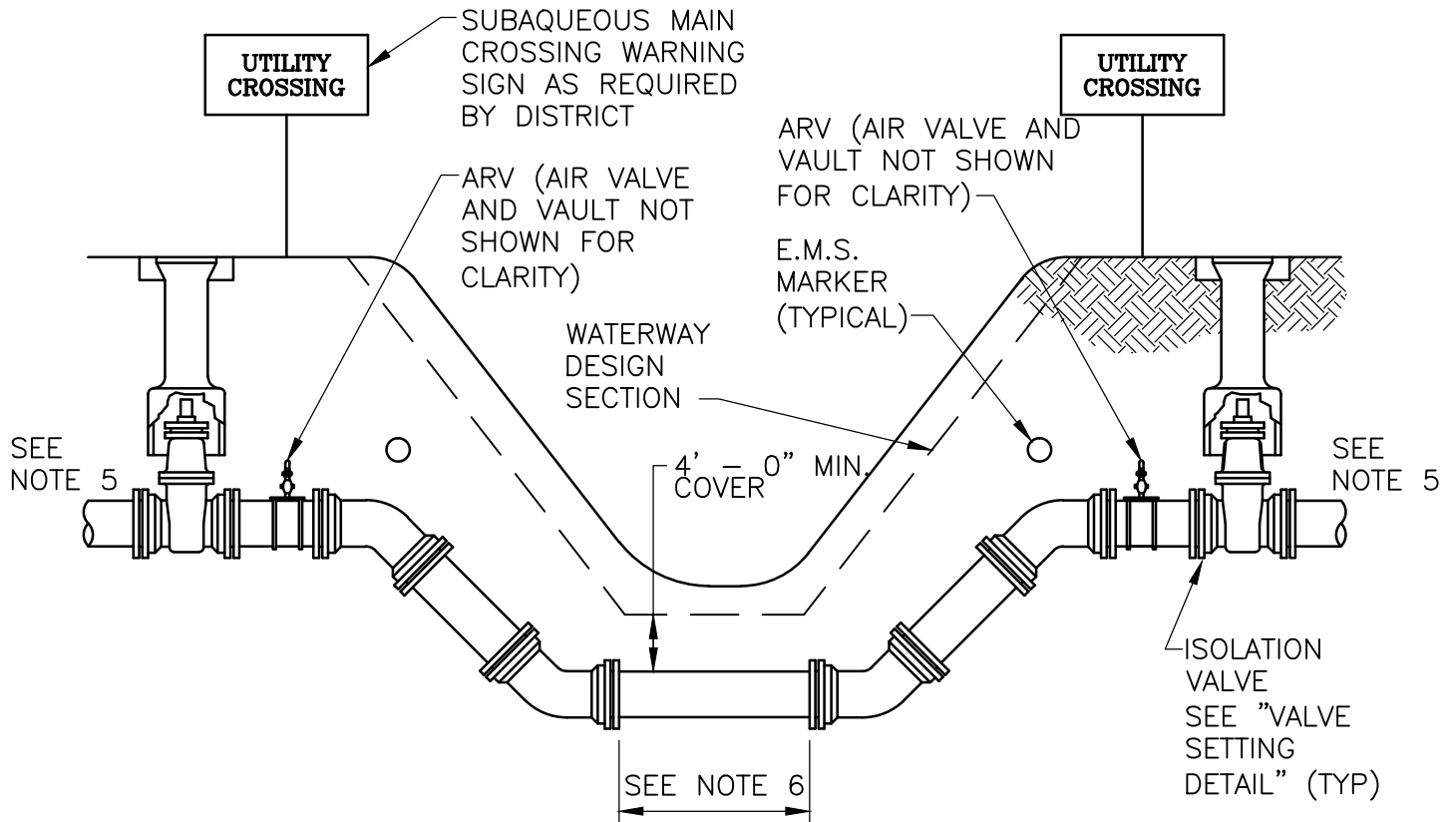

**NOTES:** (PLEASE REFER TO WRITTEN SPECIFICATIONS FOR ADDITIONAL REQUIREMENTS)

1. IN SOME CASES AIR RELIEF VALVES MAY BE REQUIRED.
2. EXACT LOCATION AND NUMBER OF BLOWOFFS, VALVES, SIGNS, AND E.M.S. MARKERS TO BE DETERMINED IN THE FIELD BY A DISTRICT INSPECTOR.
3. IF WATERWAY IS NOT CUT TO THE DESIGN CROSS SECTION, THE 4'-0" MINIMUM COVER SHALL APPLY TO THE DEEPER SECTION, WHETHER EXISTING OR DESIGN.
4. ISOLATION VALVES MAY BE DELETED ON SOME FORCE MAIN INSTALLATIONS. ENGINEER OF RECORD SHALL OBTAIN WRITTEN PERMISSION FROM DISTRICT TO DELETE PLUG VALVES.
5. PIPE SHALL BE RESTRAINED FOR A MINIMUM DISTANCE OF 60' FROM EACH TOP DEFLECTION. SEE "PIPE RESTRAINT TABLE" DETAIL FOR ADDITIONAL RESTRAINT DISTANCES.
6. WHEN THIS DISTANCE EXCEEDS ONE LENGTH OF PIPE THIS DETAIL DOES NOT APPLY AND CLASS 56 DUCTILE IRON BALL & SOCKET PIPE SHALL BE USED FROM VALVE TO VALVE. DEFLECTION OF BALL & SOCKET PIPE NOT TO EXCEED 15'
7. FOR WATER MAINS 1" PERMANENT TAPS SHALL BE PROVIDED ON BOTH SIDES OF THE ISOLATION VALVE CLOSEST TO THE SUPPLY SOURCE. 1" POLYETHYLENE TUBING AND CORP STOP SHALL BE EXTENDED FROM EACH TAP TO AN APPROVED METER BOX.

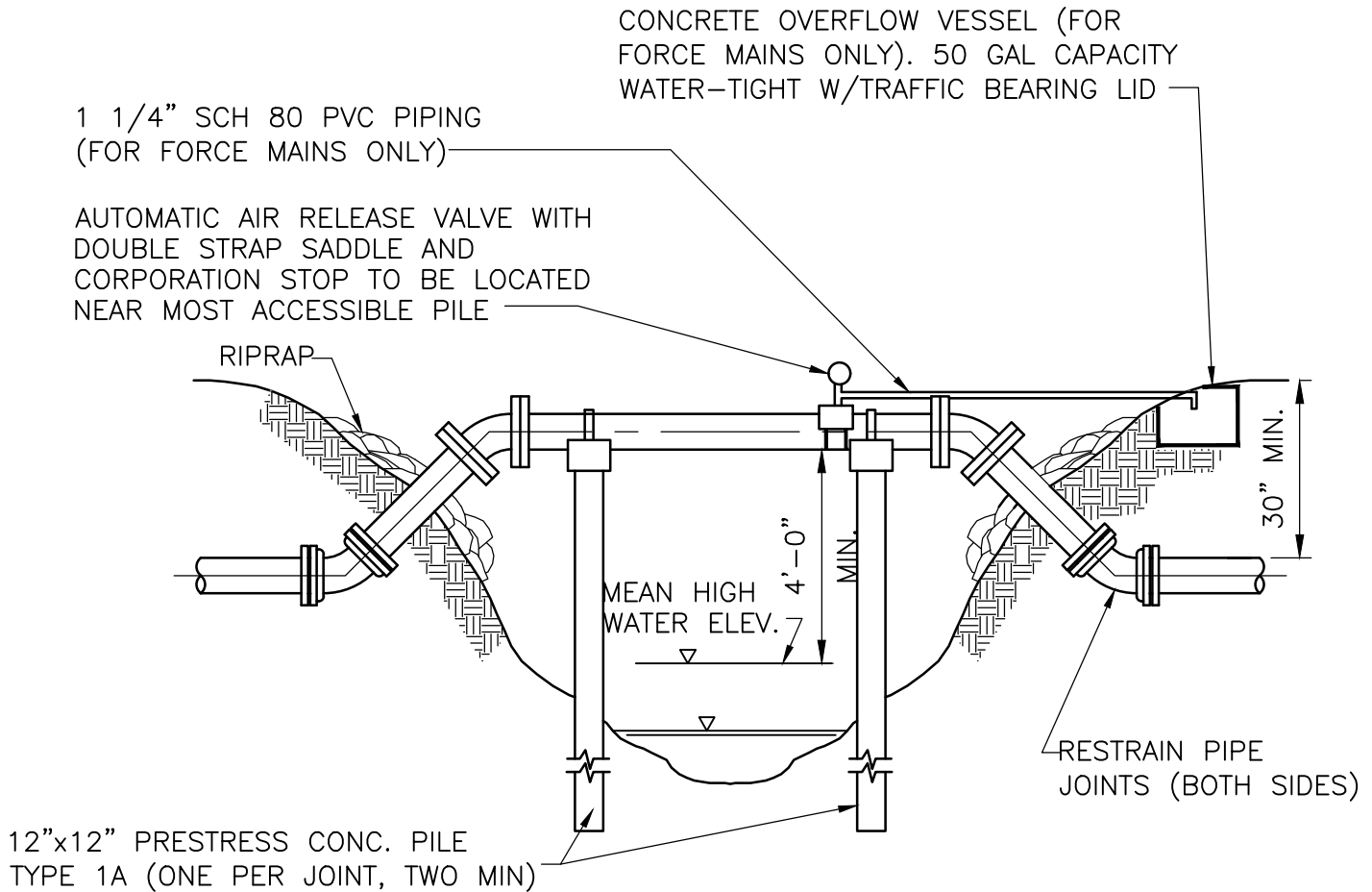

**NOTES:**

1. ALL EXPOSED PIPES SHALL BE DUCTILE IRON WITH FLANGED FITTINGS TYPE.
2. SPAN HEIGHT AS REQUIRED BY PERMITTING AGENCY.
3. MAXIMUM SUPPORT SPACING SHALL BE IN ACCORDANCE TO MANUFACTURERS RECOMMENDATION.
4. FAN GUARDS ARE REQUIRED, SEE "FAN GUARD" DETAIL (NOT SHOWN).
5. ALL EXPOSED PIPING, GUARDS AND FITTINGS SHALL BE PAINTED WITH AN APPROVED COATING SYSTEM.
6. PIPE SHALL BE CRADLED ON NEOPRENE PAD.
7. TIE-DOWN STRAPS MUST PROPERLY FIT AND SECURE PIPE IN CRADLE.
8. THE PILES SHALL BE DRIVEN TO A MINIMUM PENETRATION OF 20'-0" UNLESS THE PRESENCE OF POOR SOILS (N<3) NECESSITATE A DEEPER PENETRATION.
9. PROVIDE TWO FULL LENGTHS OF RESTRAINED D.I.P. BOTH SIDES OF CROSSING.
10. CONTINUE LOCATOR WIRE ACROSS CANAL CROSSING.

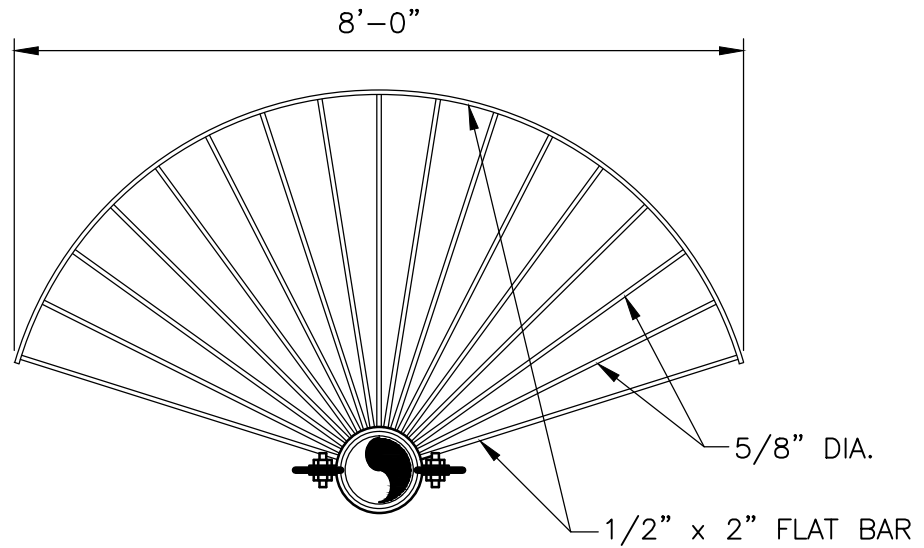

ELEVATION

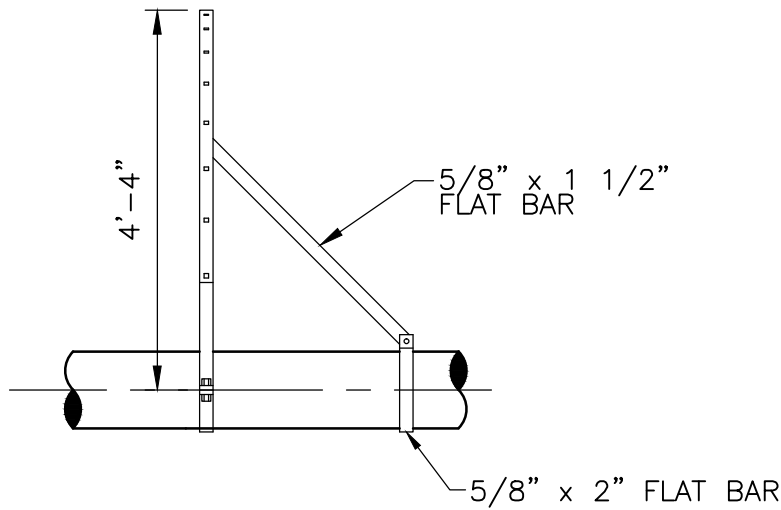

SIDE VIEW

NOTES:

1. FAN GUARDS SHALL BE PLACED AT EACH END OF CANAL CROSSING.
2. FAN GUARD AND ALL MOUNTING BRACKETS TO BE HOT DIP GALVANIZED AND MOUNTING HARDWARE TO BE STAINLESS STEEL.
3. 1/2" THICK NEOPRENE PAD TO INSULATE PIPE FROM CONTACT WITH ALL MOUNTING HARDWARE, FAN GUARD HARDWARE, AND CONCRETE SURFACES.

TOP RAIL 1 5/8" O.D.  
GSP SCHD. 40

2 1/2" O.D. GSP  
SCHD. 40 SPACED  
AT 10'-0" MAX.

7 GA. AL. COATED  
TENSION WIRE

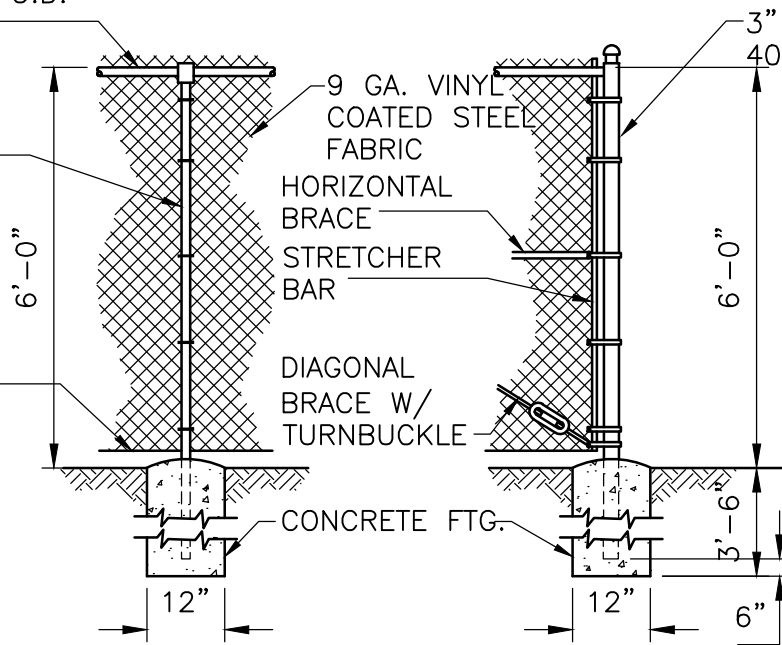

LINE POST

CORNER POST

GATE RAIL & POSTS 1 5/8"  
O.D. GSP SCHD. 40

WATERPROOF CAP

STRETCHER BAR  
DROP BAR W/  
PADLOCK AND  
HASP

DIAGONAL BRACE ROD  
W/ TURNBUCKLE

1" DIA. SCHD. 40  
IN CONCRETE FTG.

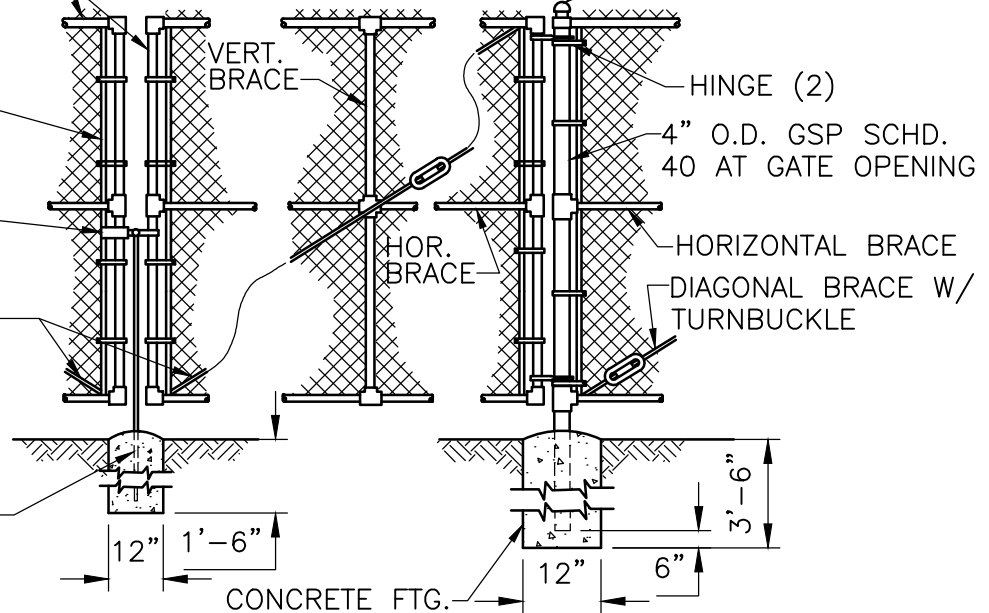

GATE

GATE POST

NOTES:

1. GATE TO BE 14'-0" CLEAR OPENING MINIMUM.
2. VINYL COATED STEEL WOVEN WIRE FABRIC TO BE STRETCHED TAUT W/ STRETCHER BARS AND STRAPS AND FASTENED TOP & BOTTOM AND AT LINE POSTS WITH GALV. PIG RING TIES WITH SLATS.
3. GATE TO BE SECURED OPEN WITH GATE STOP SET IN CONCRETE.
4. ALL RAILS, POSTS AND HARDWARE TO BE VINYL COATED.
5. DISTRICT TO APPROVE COLOR OF FENCING AND SLATS.

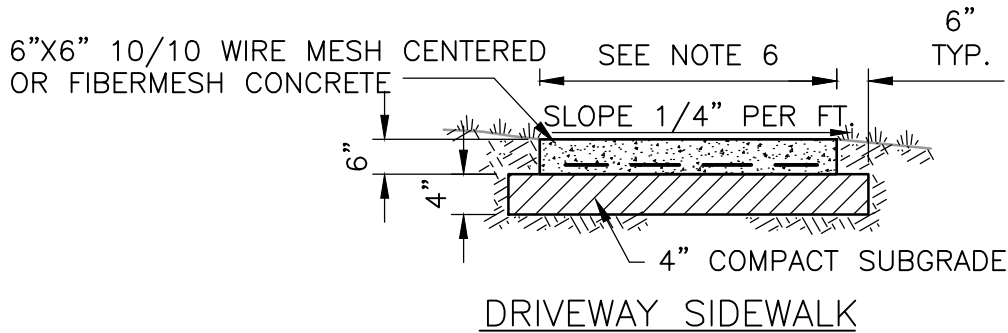
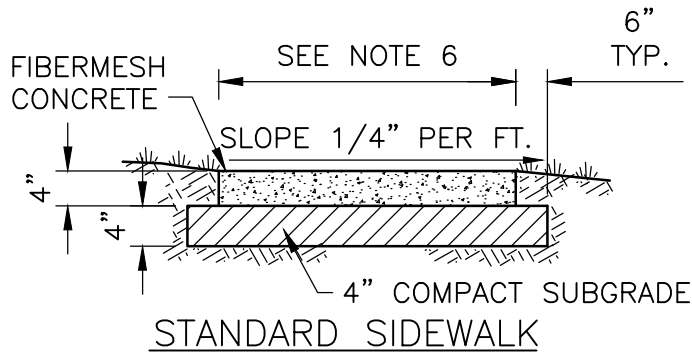

GENERAL CONSTRUCTION NOTES:

1. CONCRETE STRENGTH TO BE 2,500 P.S.I. AT 28 DAYS.
2. TOOLED DUMMY CONTRACTION JOINTS EVERY 5' (TYPE 'B' JOINTS) OR MATCH EXISTING.
3. EXPANSION JOINTS W/PREMOLDED FILLER AT 100' O/C (TYPE 'C' JOINTS)
4. SUBBASE TO BE 50 F.B.V. 98% DENSITY PER ASTM D-1557.
5. WHERE APPLICABLE, THE LOCAL MUNICIPALITY SIDEWALK DETAIL WILL GOVERN.
6. MATCH EXISTING SIDEWALK OR AS DIRECTED BY ENGINEER OF RECORD AND DISTRICT.

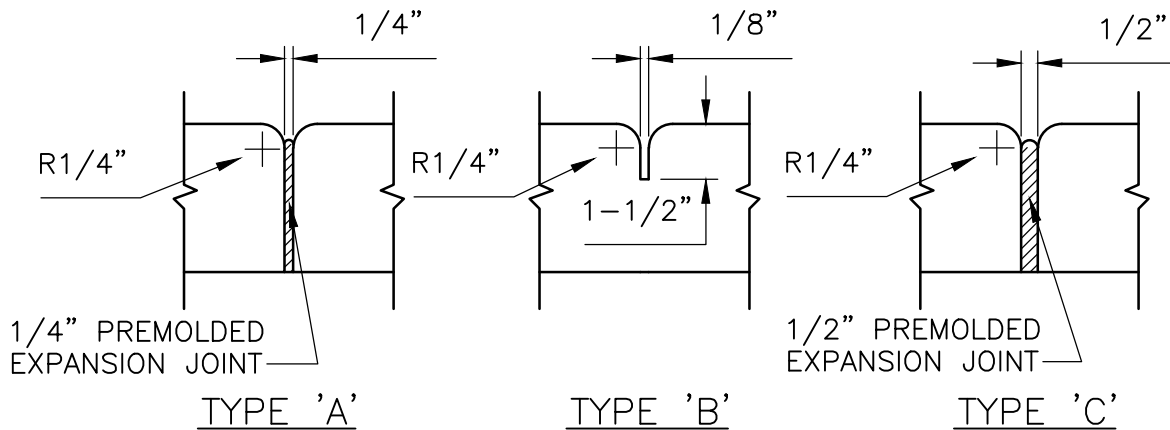

- TYPE 'A' AT P.C. & P.T. OF CURVES AND AT JUNCTION OF EXISTING AND NEW SIDEWALKS
- TYPE 'B' 5'-0" CENTER TO CENTER ON NEW SIDEWALKS
- TYPE 'C' WHERE NEW SIDEWALK ABUTS CONCRETE CURBS, DRIVEWAY AND SIMILAR STRUCTURES



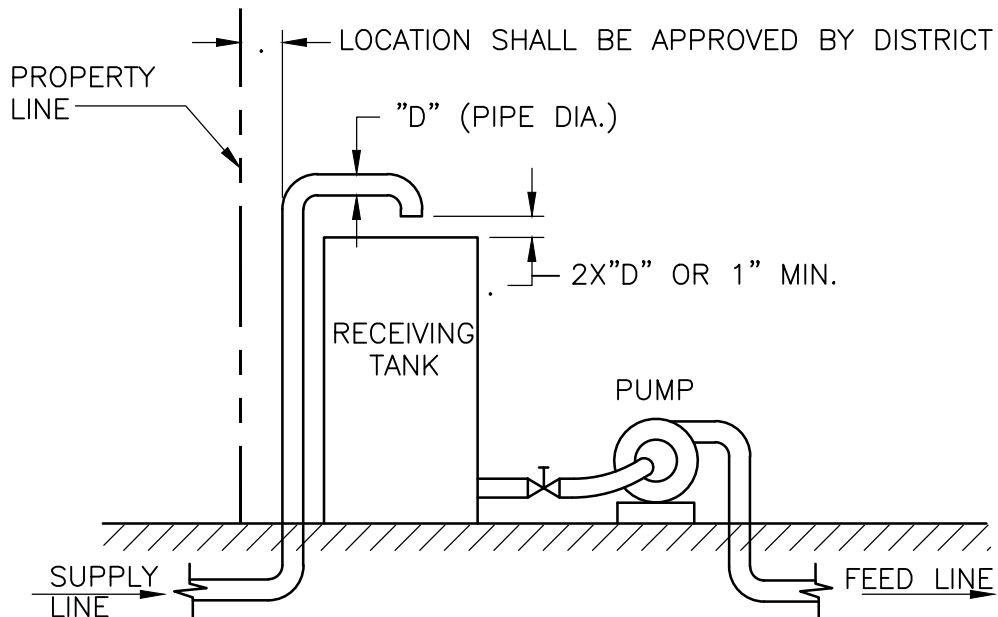

NOTES:

1. THROUGH THE FREE ATMOSPHERE BETWEEN THE LOWEST OPENING FROM ANY PIPE OR FAUCET SUPPLYING WATER TO A TANK, PLUMBING FIXTURE OR OTHER DEVICE AND THE FLOOD LEVEL OR OVERFLOW RIM OF THE RECEPTACLE.
2. THE "APPROVED AIR GAP SEPARATION" SHALL BE AT LEAST DOUBLE THE DIAMETER OF THE SUPPLY PIPE MEASURED VERTICALLY ABOVE THE OVERFLOW RIM OF THE VESSEL AND IN NO CASE SHALL THE GAP BE LESS THAN ONE (1) INCH IN DIAMETER.
3. AN AIR GAP SEPARATION MEANS THE UNOBSTRUCTED VERTICAL DISTANCE.

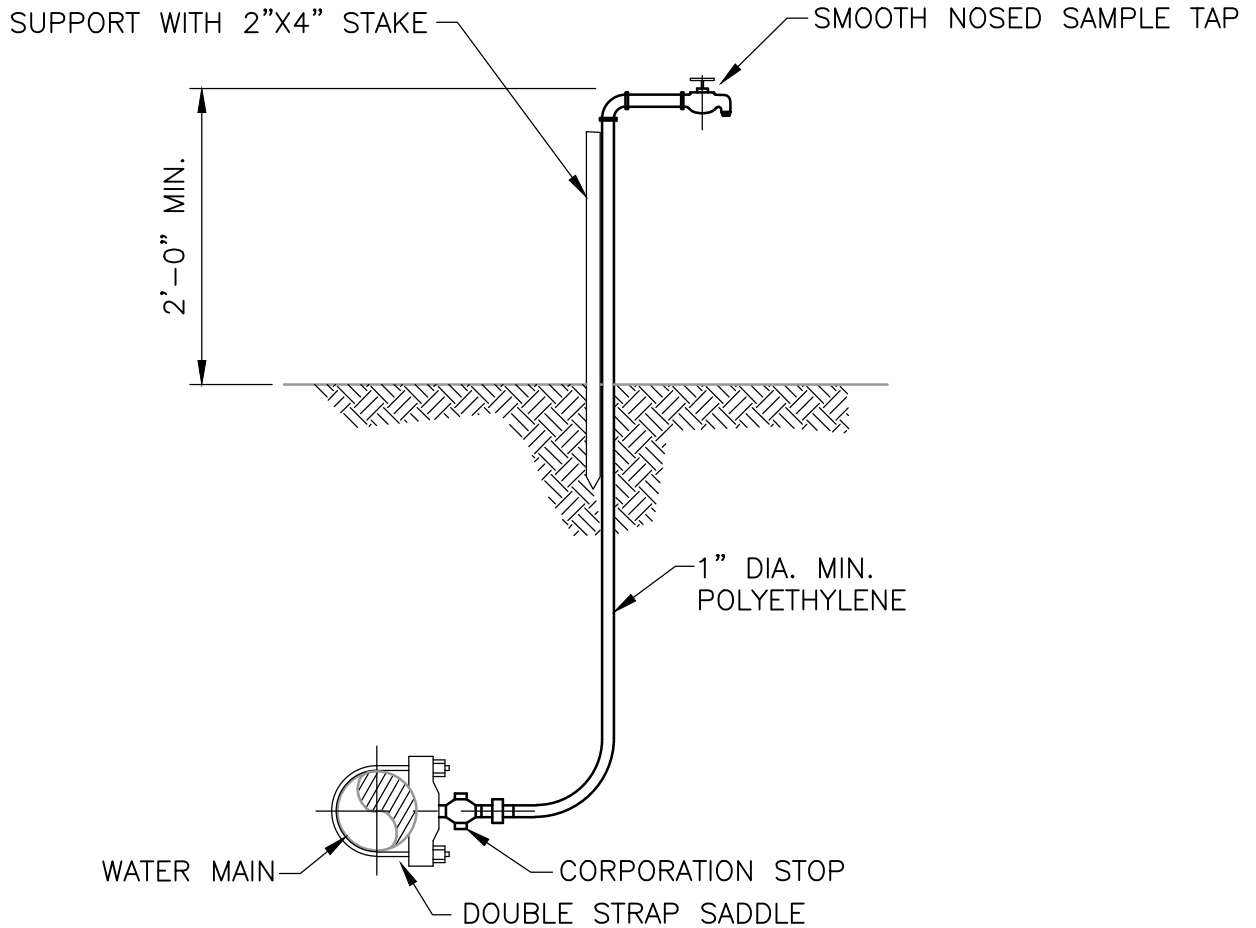

NOTES:

1. SAMPLE POINT SHOULD BE A SERVICE LINE OR FIRE HYDRANT IF POSSIBLE.
2. AFTER SAMPLING IS COMPLETED AND APPROVED, SHUT OFF CORP. STOP, REMOVE TUBING, PLUG WITH BRASS PLUG AND LOCATE FOR RECORD DRAWINGS.
3. MOUNT METAL OR PLASTIC TAG INDICATING "SAMPLE POINT – DO NOT TURN OFF"

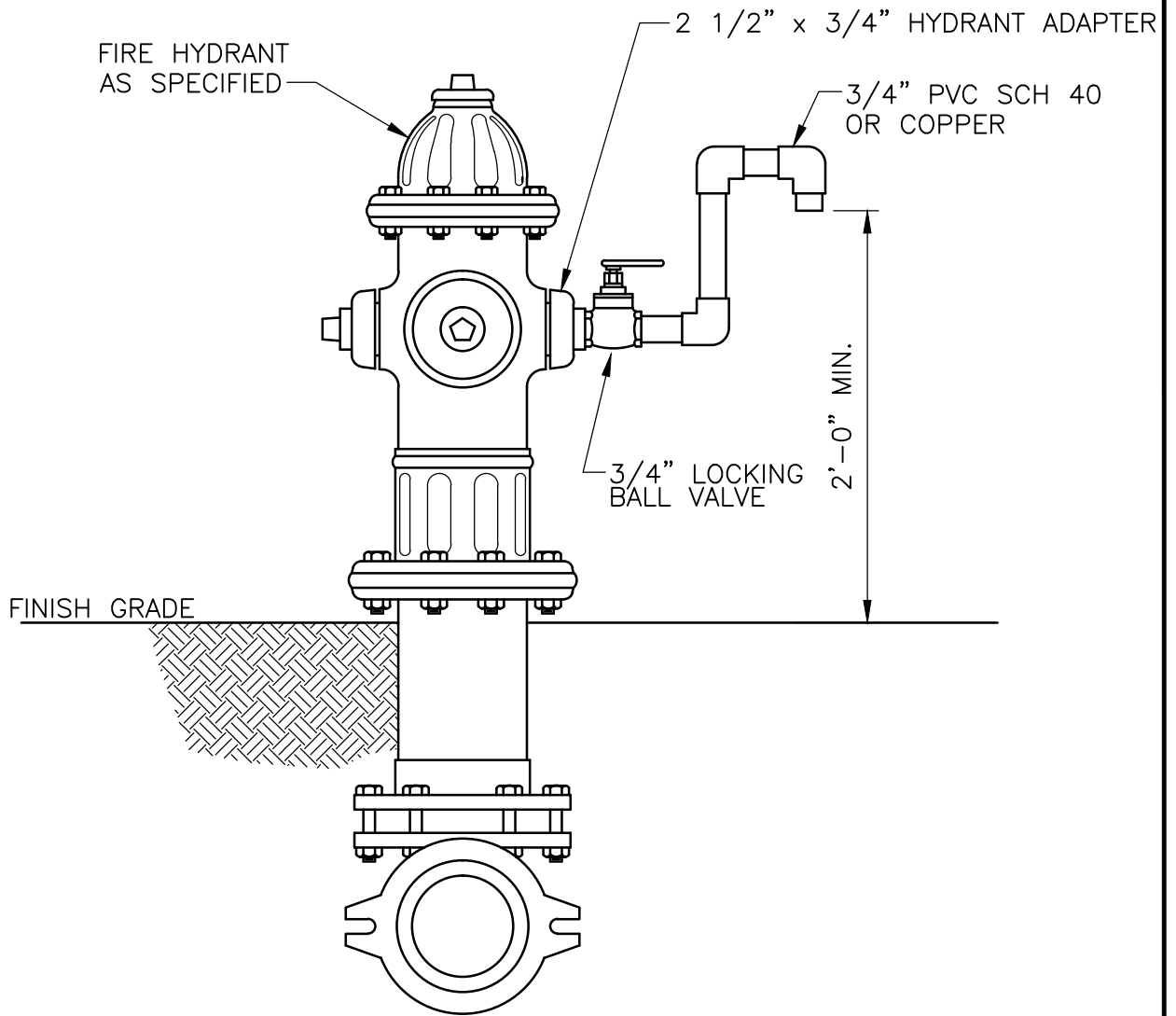

PLEASE REFER TO WRITTEN SPECIFICATIONS FOR ADDITIONAL REQUIREMENTS

2 1/2" BRASS NSFT  
DISCHARGE WITH CAP  
AND CHAIN

FLUSH HYDRANT BOX w/ LID LABELED "WATER"  
TO BE SUPPLIED BY CONTRACTOR (POLYMER  
CONCRETE AND FIBER REINFORCED POLYESTER.)  
17"x30" CDR SYSTEMS, OR APPROVED EQUAL.

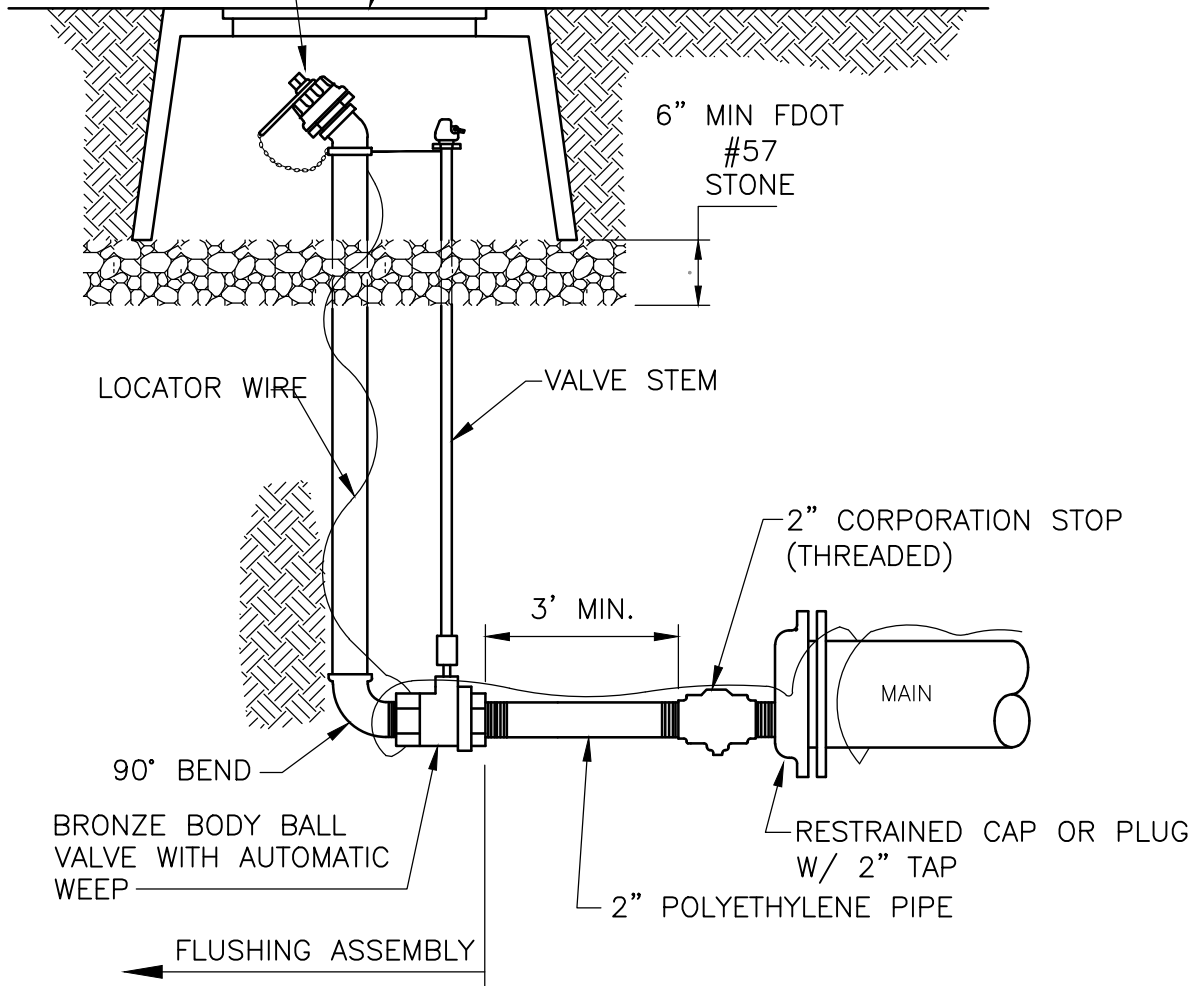

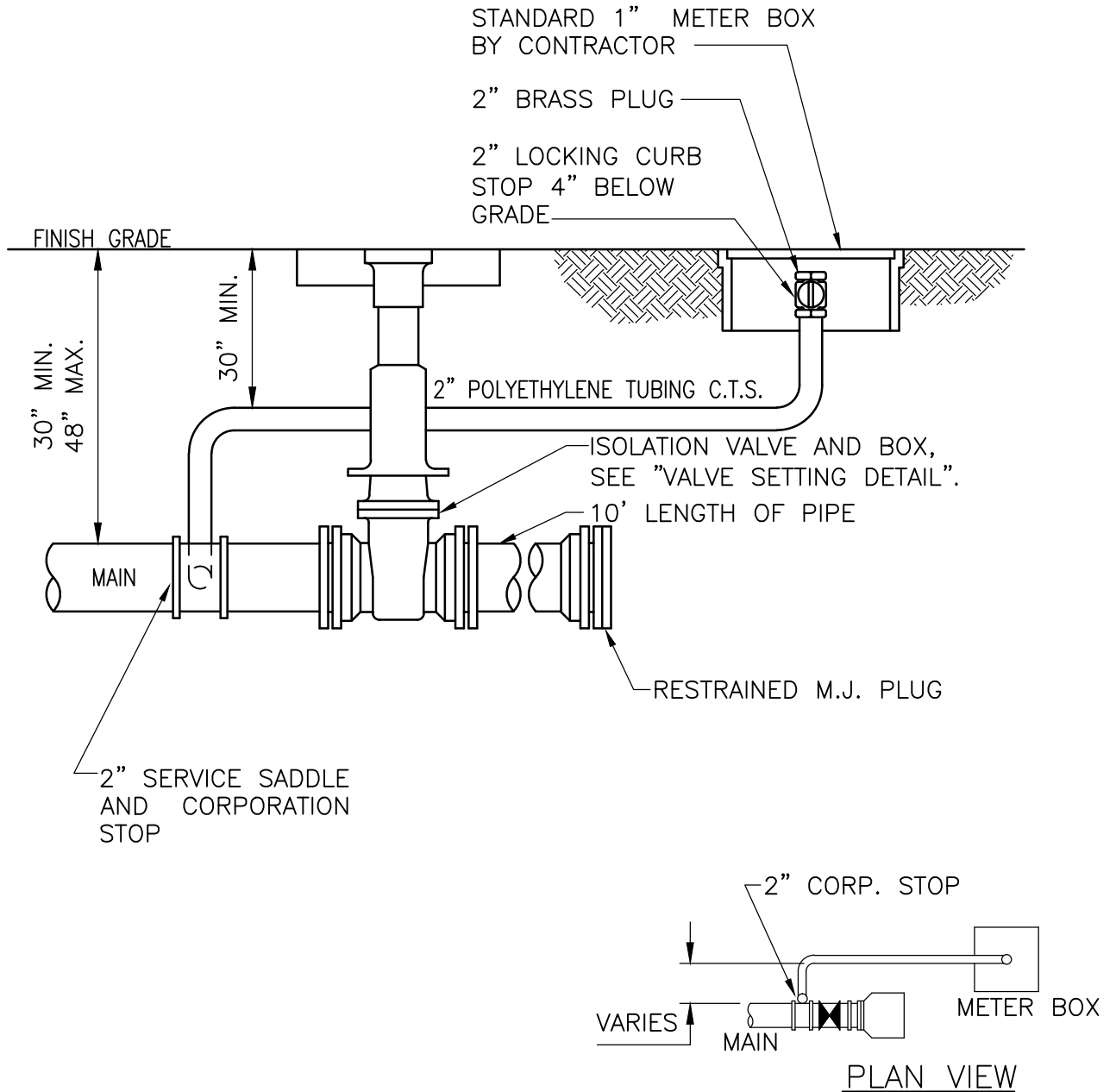

NOTES:

1. TRAFFIC BEARING METER BOXES WILL BE REQUIRED IN ALL PAVED AREAS AND AREAS WHICH MAY BE PAVED IN THE FUTURE.
2. TUBING SHALL BE CONTINUOUS FROM CORPORATION STOP TO CURB STOP, NO FITTINGS SHALL BE PERMITTED.
3. PREVIOUS JOINTS SHALL BE RESTRAINED IN ACCORDANCE WITH "MECHANICAL JOINT ANCHORING REQUIREMENTS" DETAIL.

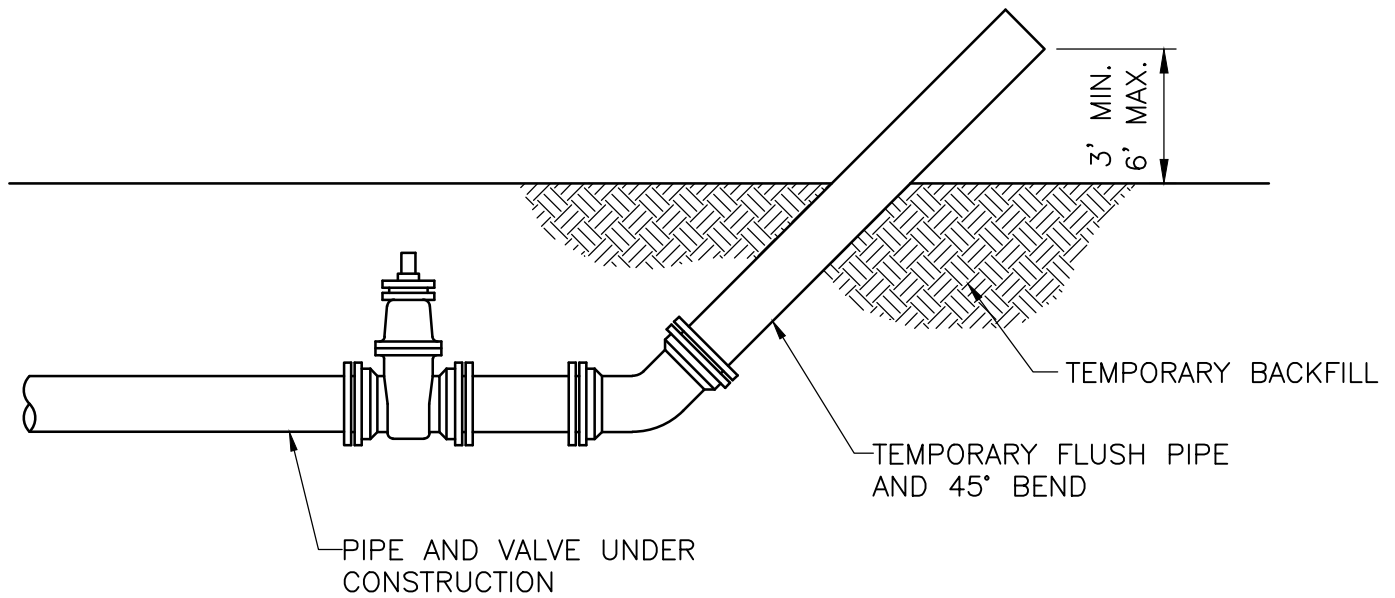

**NOTES:** (PLEASE REFER TO WRITTEN SPECIFICATIONS FOR ADDITIONAL REQUIREMENTS)

1. UPON COMPLETION OF THE PIPE INSTALLATION FOR ANY SECTION, THE MAINS SHALL BE CANNON FLUSHED TO REMOVE DIRT AND ANY OTHER FOREIGN MATTER BY ACHIEVING A MINIMUM VELOCITY OF 2.5 FEET PER SECOND IN THE PIPE. TEMPORARY FITTINGS, PIPE, ETC. MAY BE NEEDED TO FACILITATE CANNON FLUSHING.
2. INSTALL A 45° BEND AND ASSOCIATED PIPING AS SHOWN TO DIRECT THE FLUSHING WATER AWAY FROM THE IMMEDIATE WORK AREA, EXERCISE DUE CARE TO ENSURE THAT THE WATER USED IN FLUSHING DOES NOT CAUSE A NUISANCE OR CAUSE PROPERTY DAMAGE.
3. BENDS AND PIPING SHALL BE THE SAME SIZE AS THE LINE TO BE FLUSHED.
4. PRIOR TO THE ACTUAL LINE FLUSHING OPERATION, THE CONTRACTOR SHALL NOTIFY DISTRICT OF SUCH INTENDED WATER USE.
5. NO EXISTING VALVES SHALL BE TURNED ON OR OFF, EXCEPT BY AUTHORIZED DISTRICT PERSONNEL.
6. FLUSHING SHALL NOT BE ACCOMPLISHED WITHOUT THE ACTUAL PRESENCE OF A DISTRICT REPRESENTATIVE.
7. AFTER THE LINE UNDER CONSTRUCTION HAS BEEN SUCCESSFULLY FLUSHED THE CONTRACTOR SHALL REMOVE THE TEMPORARY PIPING ARRANGEMENT AND PROCEED WITH THE REMAINING CONSTRUCTION AS SPECIFIED.
8. THERE ARE SPECIAL REQUIREMENTS FOR CLEANING AND FLUSHING PIPE LARGER THAN 12".
9. THE CONTRACTOR SHALL PAY FOR ALL WATER UTILIZED IN THE FLUSHING PROCESS. THE AMOUNT OF WATER REQUIRED WILL BE FORWARDED TO THE DISTRICT 24 HOURS PRIOR TO FLUSHING.

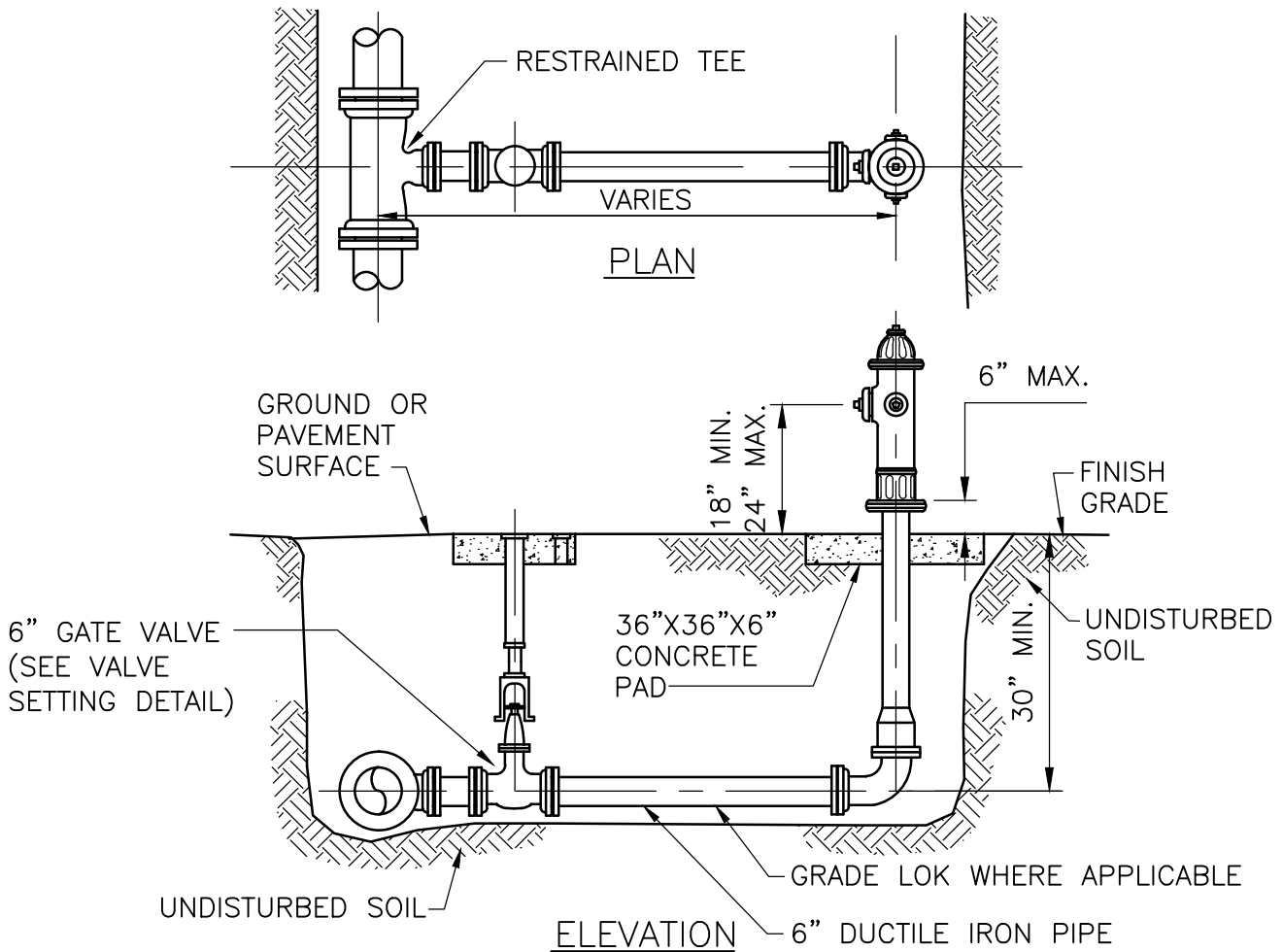

**NOTES:**

1. HYDRANTS SHALL BE INSTALLED PLUMB AND TRUE.
2. VALVES SHALL BE PLACED ADJACENT TO MAIN, AND TIED TO TEE.
3. PUMPER NOZZLE SHALL FACE STREET.
4. ALL HYDRANTS SHALL BE CONNECTED TO THE MAIN WITH RESTRAINED TEE.
5. HYDRANTS SHALL NOT BE PLACED IN SIDEWALK, ROADWAYS OR BIKEPATHS.
6. ALL PIPE AND FITTINGS SHALL BE RESTRAINED.
7. HYDRANT BARREL COLOR TO BE RED.
8. THE CONNECTOR PIPE SHALL BE CEMENT LINED DUCTILE IRON, CLASS 350.
9. HYDRANT EXTENSIONS SHALL NOT BE ALLOWED.
10. NEWLY CONSTRUCTED FIRE HYDRANTS THROUGHOUT THE PROJECT SHALL HAVE A RED "OUT OF SERVICE" DISK (JOSEPH G. POLLARD CO. OR EQUAL) ATTACHED TO 6" PUMPER NOZZLE CAP. DISK TO BE REMOVED AFTER WATER SYSTEM HAS BEEN APPROVED FOR SERVICE BY THE DISTRICT.

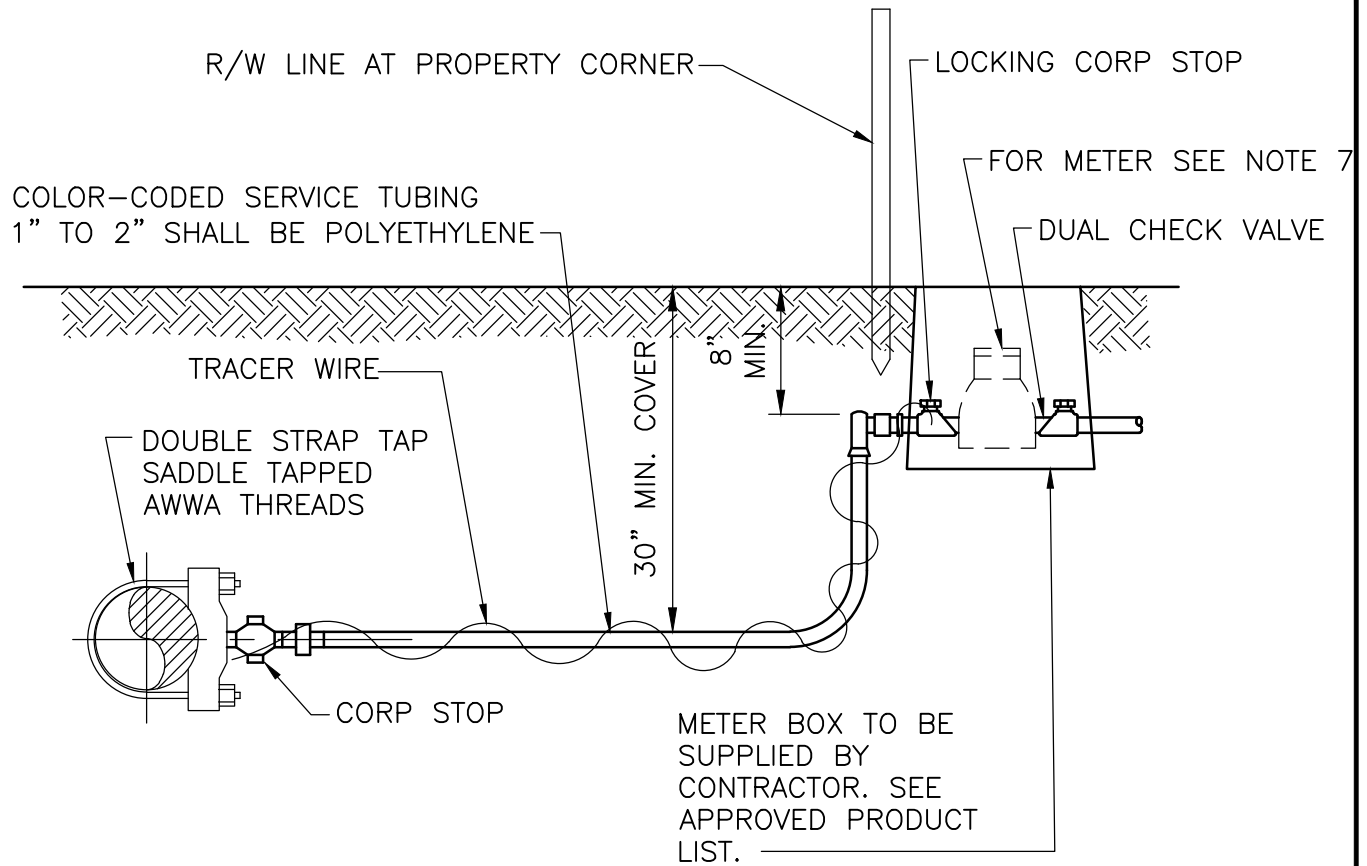

**NOTES:**

1. MIN. SERVICE LINES SHALL BE AS FOLLOWS: 1" MINIMUM FOR SINGLE AND DOUBLE SERVICES WHERE METER SIZE IS 5/8"; 2" MINIMUM FOR SINGLE AND DOUBLE SERVICES WHERE METER SIZE IS 1".
2. COMPRESSION FITTINGS SHALL BE SUITABLE FOR TUBING USED AND REQUIRE METAL (S.S.) INSERTS.
3. DOUBLE SERVICES REQUIRE "U" BRANCH WITH ANGLE CURB STOPS.
4. TUBING SHALL BE MARKED WITH SIZE, MANUFACTURERS NAME, WORKING PRESSURE, NATIONAL SANITATION FOUNDATION APPROVAL, A.S.T.M. SPECIFICATION AND PRODUCTION CODE. TUBING SHALL HAVE AN OUTSIDE DIAMETER EQUIVALENT TO THE OUTER DIAMETER OF COPPER TUBING.
5. SERVICE LOCATOR WIRE SHALL BE LAID IN THE TRENCH WITH ALL SERVICES, CONNECTED TO THE MAIN WIRE AND WRAPPED AROUND THE SERVICE PIPING OR TUBING. WIRE FOR POTABLE WATER SHALL BE BLUE IN COLOR.
6. DISTRICT APPROVED METER AND CHECK VALVES SHALL BE FURNISHED BY DEVELOPER AND DELIVERED TO THE DISTRICT'S WAREHOUSE FOR STORAGE AND SUBSEQUENT INSTALLATION BY THE DISTRICT.



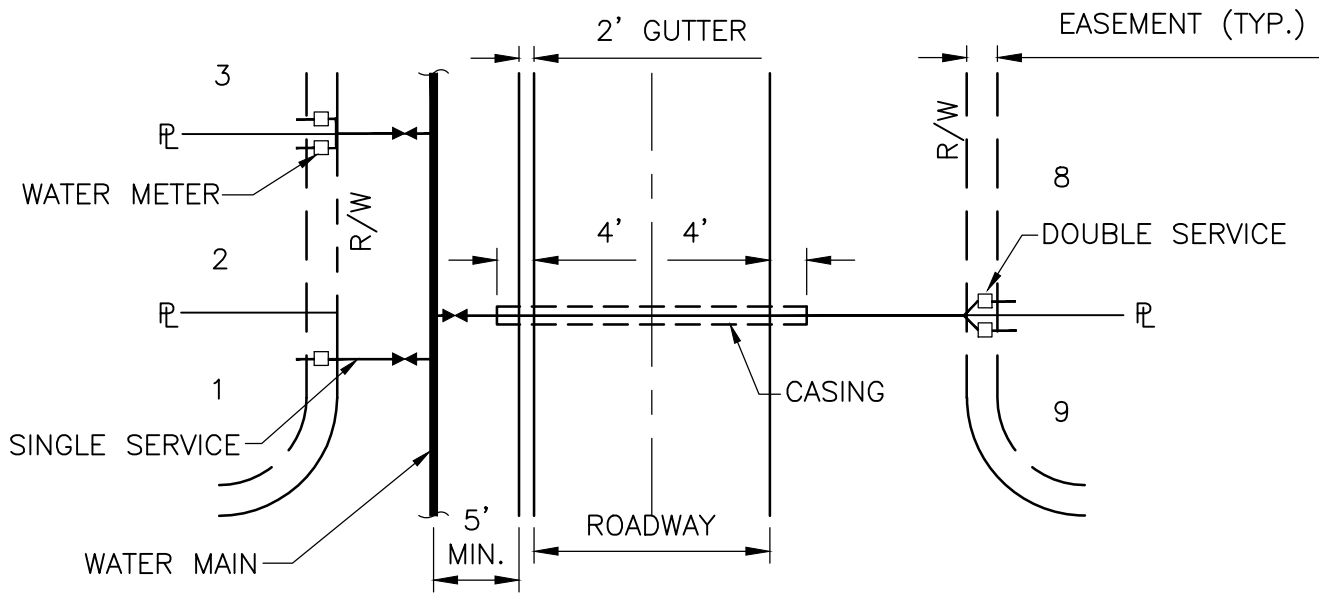

PLAN

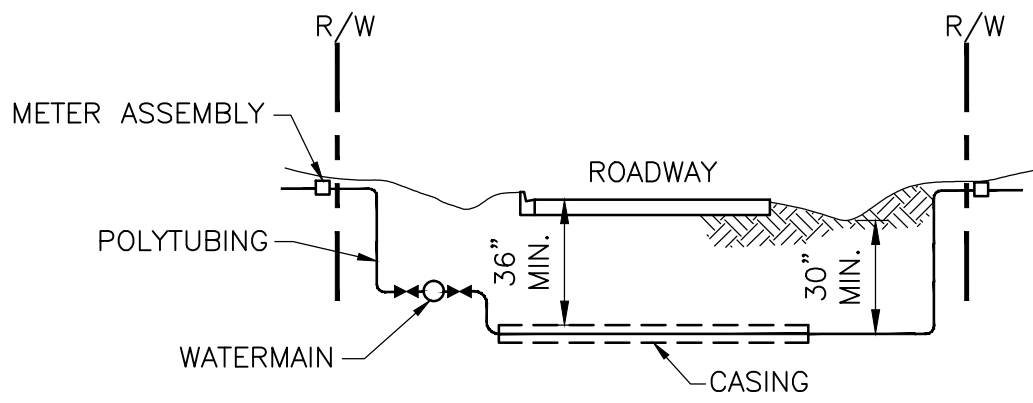

PROFILE

NOTES:

1. HOUSE SERVICE LATERAL UNDER PAVEMENT SHALL BE INSTALLED THROUGH A 3" MINIMUM PVC SCH. 80 CASING OR HDPE CASING (EXISTING ROADWAYS) UNLESS OTHERWISE APPROVED BY THE DISTRICT.
2. TAPPING SADDLE AND CORPORATION STOP MUST BE PLACED IN ACCESSABLE AREAS, OUT FROM UNDER ANY PAVED AREAS.
3. SERVICE LOCATOR WIRE SHALL BE LAID IN THE TRENCH WITH ALL SERVICES, CONNECTED TO THE MAIN WIRE AND WRAPPED AROUND THE SERVICE PIPING OR TUBING. WIRE FOR POTABLE WATER SHALL BE BLUE IN COLOR.



ST. LUCIE COUNTY  
WATER & WASTEWATER  
CONSTRUCTION  
STANDARDS

WATER SERVICE CONNECTIONS  
PLAN / PROFILE

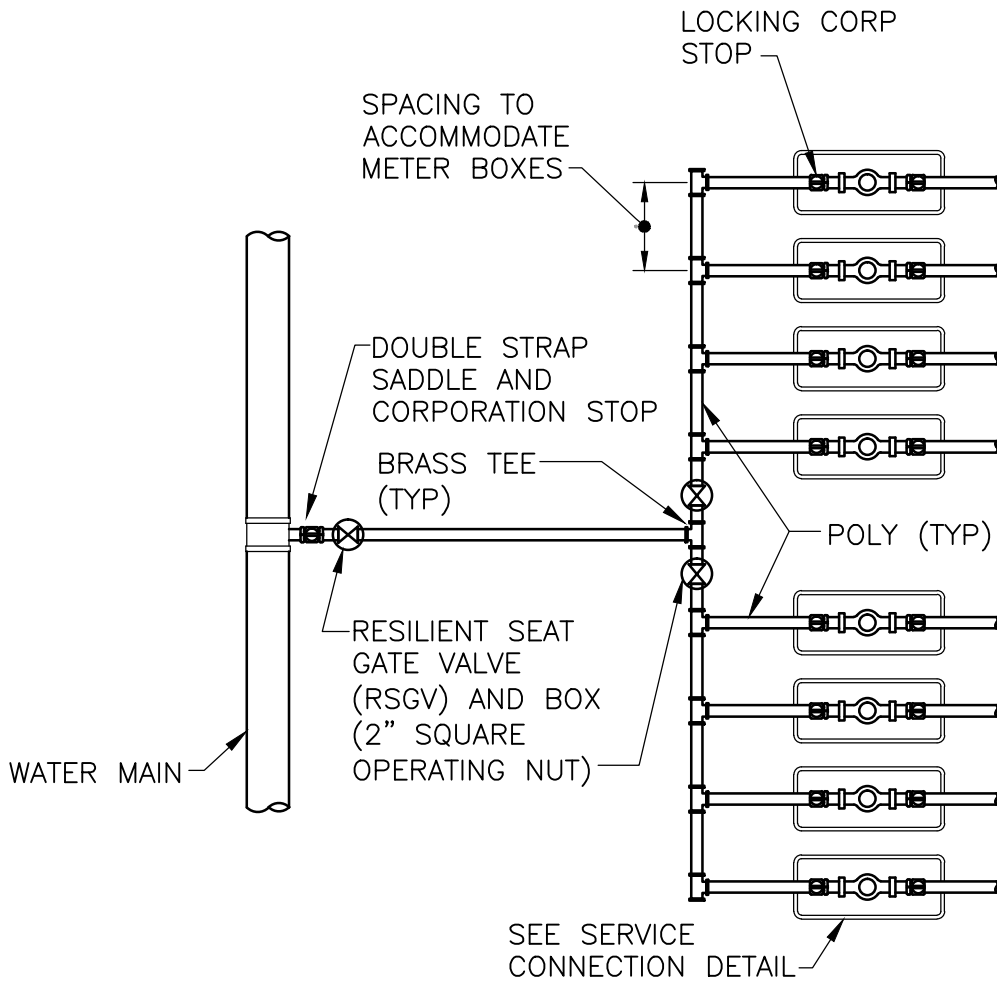

TYPICAL MULTIPLE SERVICE SIZES	
No. OF UNITS	LINE SIZES
3 - 12	2" OR 4"

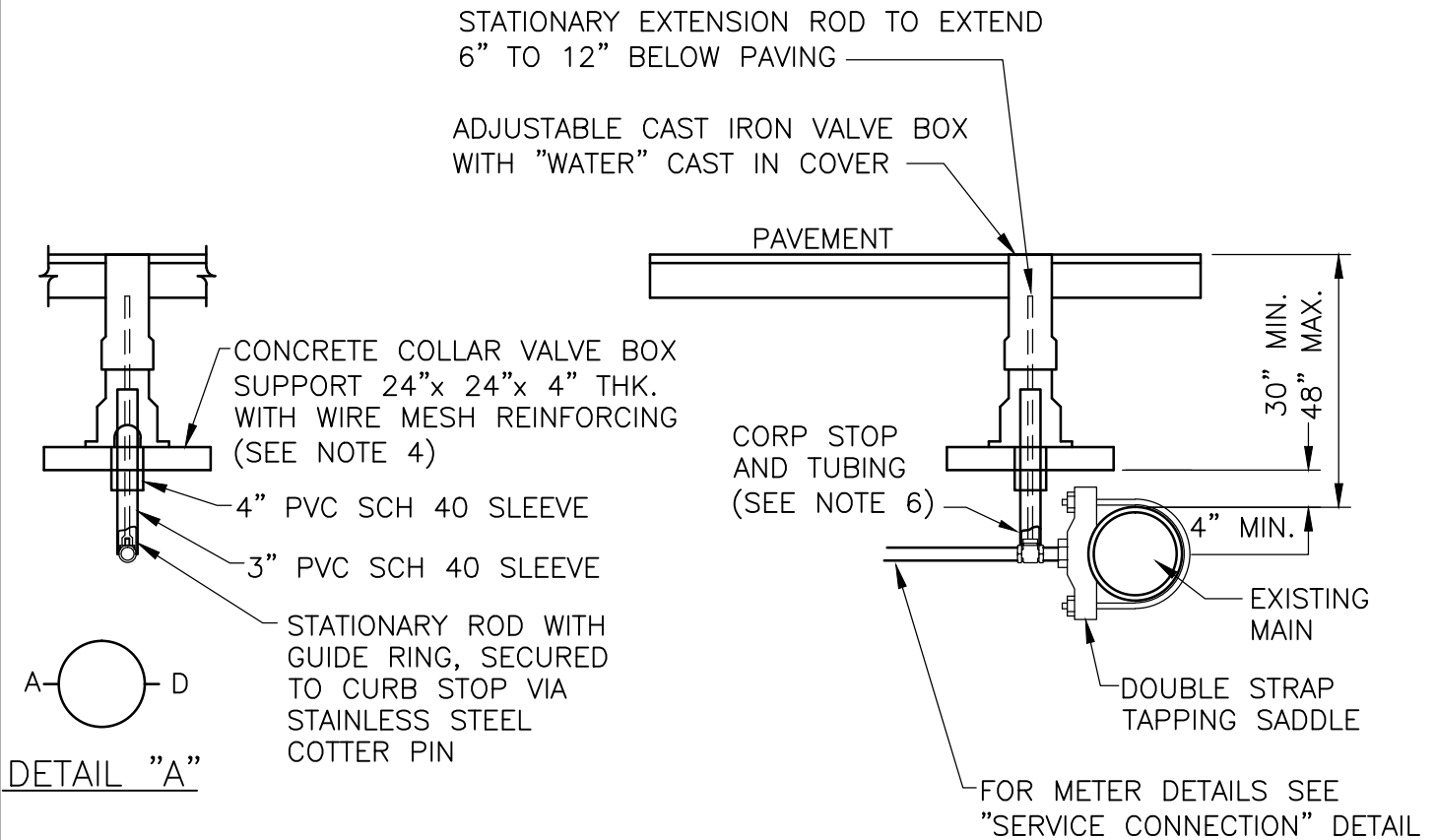

NOTES: (PLEASE REFER TO WRITTEN SPECIFICATIONS FOR ADDITIONAL REQUIREMENTS)

1. SUCCESSIVE TAPS INTO THE WATER MAIN SHALL BE SPACED A MINIMUM OF 18" OFFSET AND AT 90° FROM THE CENTERLINE AS SHOWN ON DETAIL "A".
2. SERVICE LINES SHALL BE CONTINUOUS FROM CURB STOP TO ANGLE METER STOP WITH NO FITTINGS IN BETWEEN.
3. CORPORATION STOP AT THE MAIN TO HAVE MALE AWWA THREADS ON ONE SIDE AND BE COMPRESSION ON THE OTHER SIDE.
4. CONCRETE COLLAR VALVE BOX SUPPORT TO BE PLACED ON COMPACTED SOIL TO SUPPORT VALVE BOX SO THAT A MINIMUM OF 4 INCHES EXISTS BETWEEN THE BOTTOM OF THE CONCRETE COLLAR AND THE TOP OF THE WATER MAIN.
5. SERVICE TAPS UNDER PAVEMENT WILL NOT BE ALLOWED ON NEW WATER MAINS.

CONCRETE BLOCKS WITH #5 REBAR AT CORNERS AND ON 2'-0" CENTERS, FILL VOIDS WITH 2500 P.S.I. CONCRETE

SEE APPROPRIATE VALVING ARRANGEMENT TO PROPERLY SIZE METER PIT

QUANTITY OF BOLLARDS AND SPACING (D") BETWEEN THEM SHALL BE DETERMINED ON AN INDIVIDUAL PROJECT BASIS

BOLLARDS SHALL BE COATED WITH COATING SYSTEM FOR EXPOSED METAL

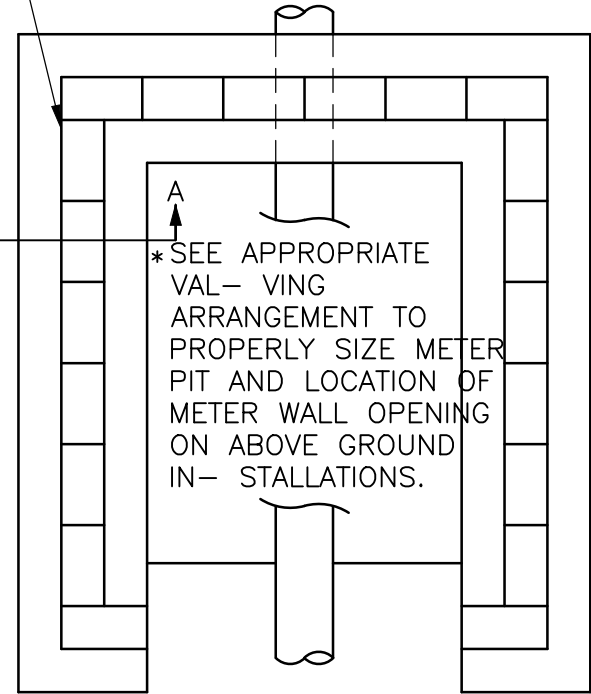

\*SEE APPROPRIATE VALVING ARRANGEMENT TO PROPERLY SIZE METER PIT AND LOCATION OF METER WALL OPENING ON ABOVE GROUND INSTALLATIONS.

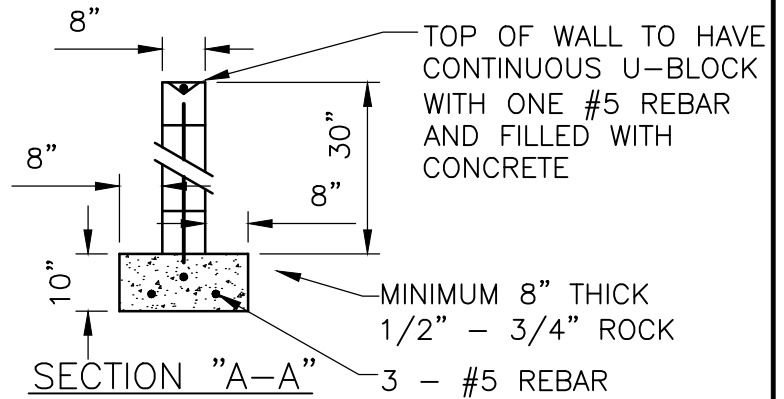
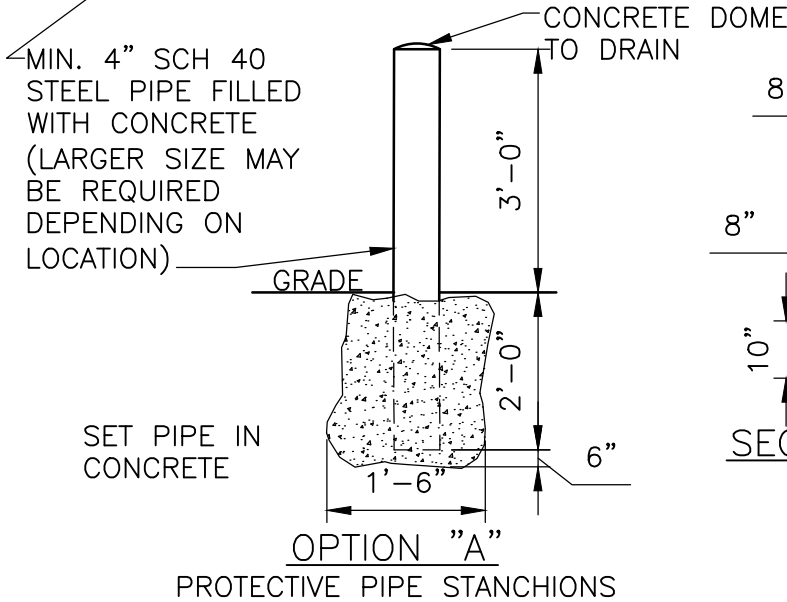

OPTION "B"  
SCREENING WALL

\* BACK FOOTER TO BE A MINIMUM OF 12" FROM PIPE ASSEMBLY AND SIDE WALLS TO BE A MINIMUM OF 36" FROM PIPE ASSEMBLY

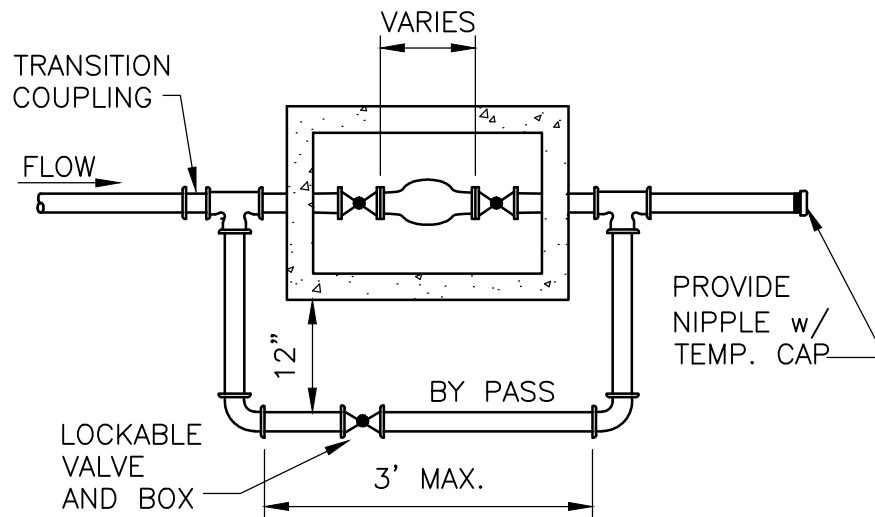

NOTES:

1. ALL VALVES TO BE STRAIGHT BALL VALVES WITH LOCK-WING. (FLANGE AT METER) FORD OR APPROVED EQUAL.
2. SEE TYPICAL SERVICE DETAIL FOR MAIN CONNECTION.
3. METER BOX SHALL BE POLYMER CONCRETE AND FIBER REINFORCED POLYESTER.
4. METER SHALL BE FURNISHED BY DEVELOPER AND DELIVERED TO THE DISTRICT'S WAREHOUSE FOR STORAGE AND SUBSEQUENT INSTALLATION BY THE DISTRICT.

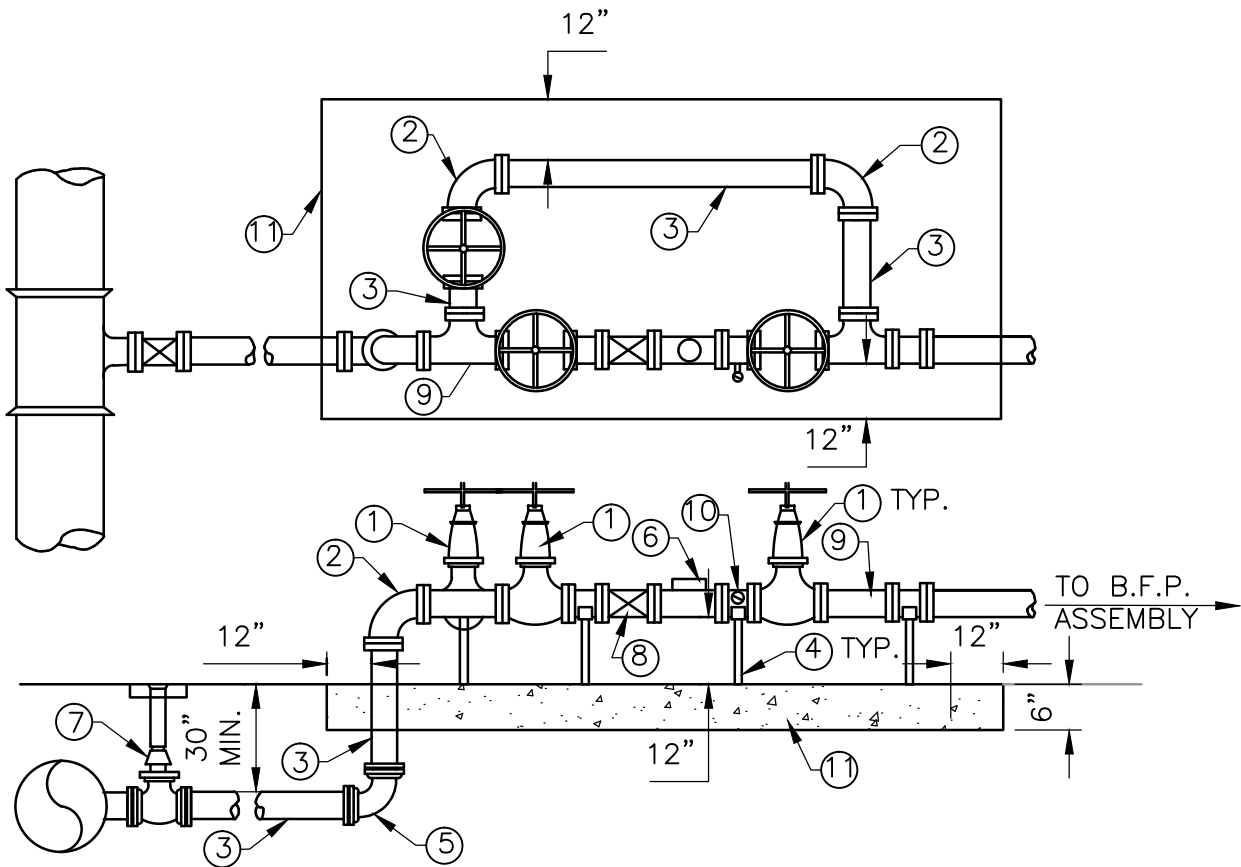

MATERIALS	
ITEM	DESCRIPTION
1	GATE VALVE (OS&Y)
2	BEND - 90 , (FLANGE - FLANGE)
3	DUCTILE IRON, PIPE
4	APPROVED PIPE SUPPORT
5	BEND-90°, (MJ-MJ)
6	METER
7	GATE VALVE AND VALVE BOX
8	WATER METER STRAINER, (FLANGE - FLANGE)
9	TEE
10	2" TAP WITH LOCKING BALL VALVE
11	CONC. SLAB, (3000 PSI MIN) W/ 6x6-W5.0xW5.0

NOTES:

1. ALL ABOVE GRADE PIPING SHALL BE DUCTILE IRON WITH FLANGED ENDS.
2. FOR 3" METER, USE 4" D.I. PIPE WITH 4"x3" REDUCER WITH FLANGED ENDS ON BOTH SIDES OF THE METER.
3. FIELD ADJUST AND CUT D.I. PIPE TO THE PROPER LENGTH AS REQUIRED.
4. METER BYPASS SHALL BE A MIN. OF 4" DIA. AND SIZED TO MEET REQUIRED FLOWS
5. ALL EXPOSED DUCTILE IRON PIPING AND FITTINGS SHALL BE PAINTED "BLUE" AS SPECIFIED. PAINT SPECIFICATIONS MUST BE SUBMITTED TO THE DISTRICT PRIOR TO APPLICATION.

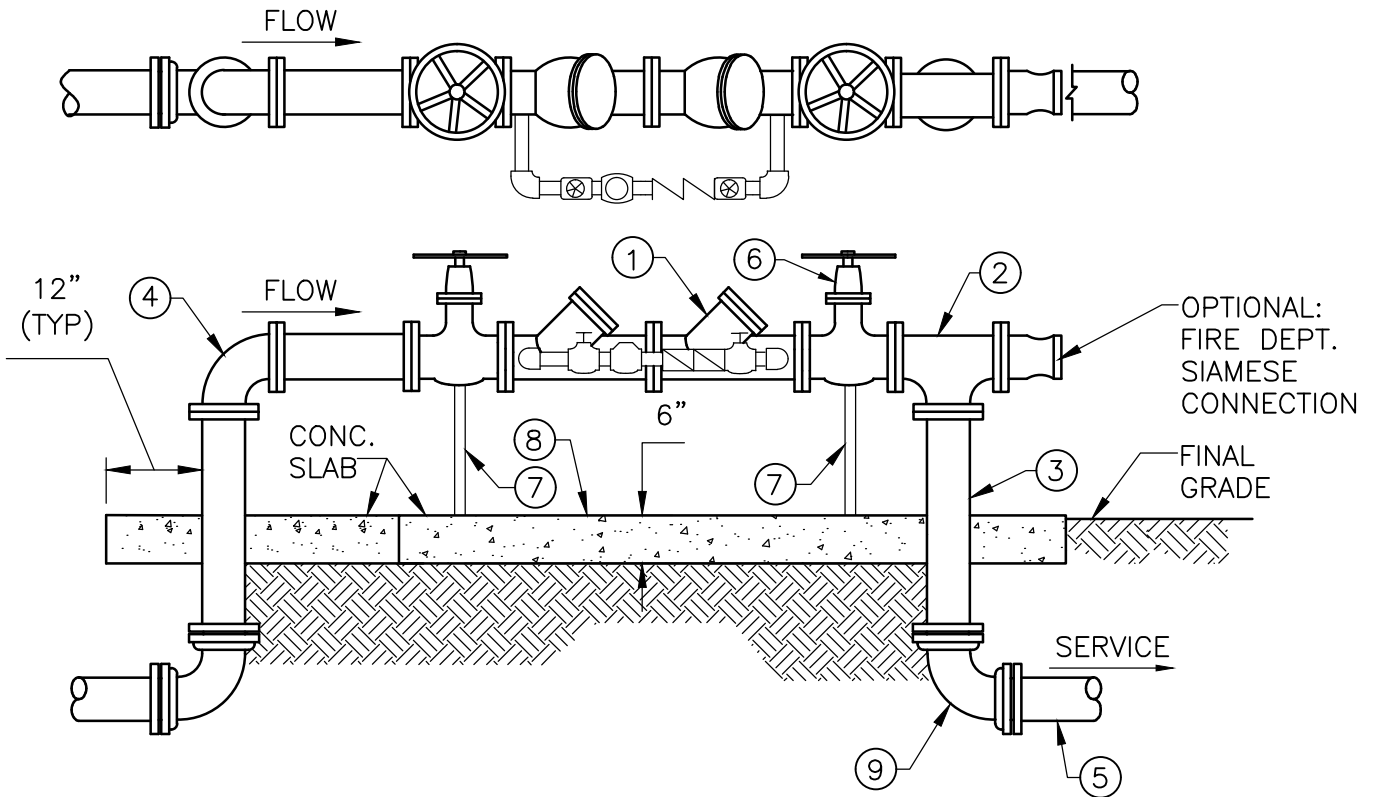

MATERIAL	
ITEM	DESCRIPTION
1	DOUBLE CHECK DETECTOR BACKFLOW PREVENTER ASSEMBLY
2	TEE ( FLANGE-FLANGE )
3	DUCTILE IRON ( CLASS 350 )
4	BEND 90° (FLANGE-FLANGE)
5	PIPE AS SPECIFIED
6	GATE VALVE, (OS&Y)
7	APPROVED PIPE SUPPORT
8	CONCRETE SLAB
9	BEND - 90° ( MJ-MJ )

**NOTES:**

1. FIELD ADJUST AND CUT ITEM 3 TO PROPER LENGTH. THIS TYPE OF CONSTRUCTION IS DESIGNED FOR LIMITED WORKING AREA.
2. ALL EXPOSED DUCTILE IRON PIPES AND FITTINGS SHALL BE PAINTED "RED" AS SPECIFIED. PAINT SPECIFICATIONS MUST BE SUBMITTED TO ST. LUCIE COUNTY UTILITIES PRIOR TO APPLICATION.
3. DETECTOR METER SHALL READ IN GALLONS AND SHALL BE 5/8" NEPTUNE MAGNETIC DRIVE, MODEL T-10, OR AS APPROVED BY THE DISTRICT.

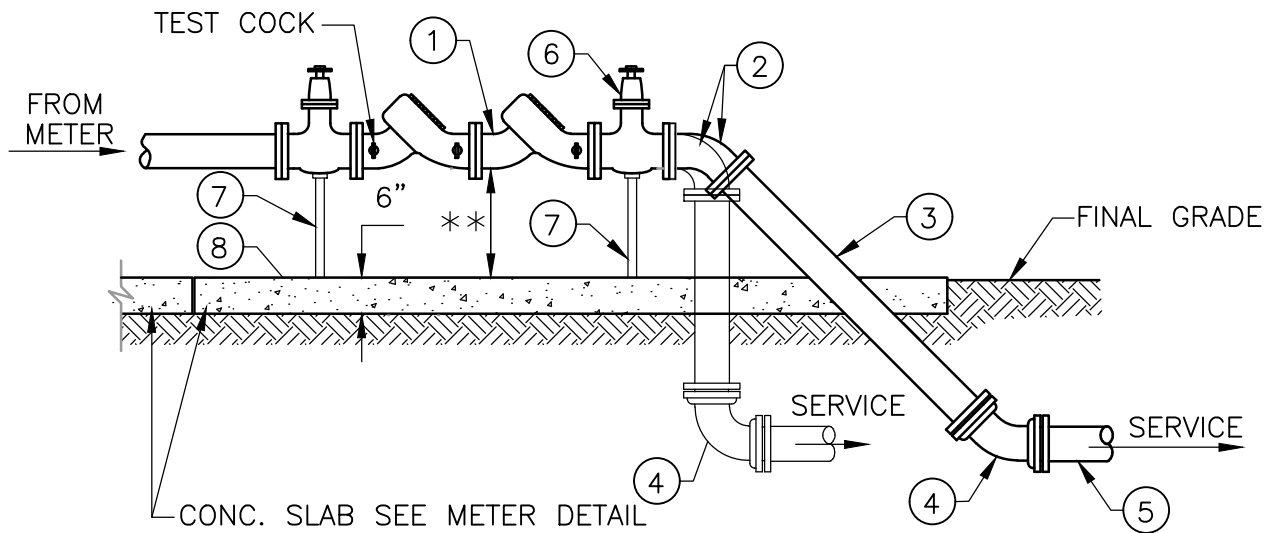

\*\* BACKFLOW TO BE THE SAME DISTANCE ABOVE GRADE AS METER

MATERIAL	
ITEM	DESCRIPTION
1	VALVE, O.C. BACKFLOW PREVENTER
2	*BEND - 45° ( FLANGE-FLANGE )
3	DUCTILE IRON PIPE
4	*BEND - 45° ( MJ-MJ )
5	PIPE, P.V.C. ( DR-18 )
6	GATE VALVE ( OS&Y )
7	APPROVED PIPE SUPPORT
8	CONCRETE SLAB (3000 PSI MIN) W/ 6x6-W5.0xW5.0

\*90° FITTINGS IN LIEU OF 45° FITTINGS ARE ACCEPTABLE.

NOTES:

1. FIELD ADJUST AND CUT ITEM 3 TO PROPER LENGTH. THIS TYPE OF CONSTRUCTION IS DESIGNED FOR LIMITED WORKING AREA.
2. ALL EXPOSED DUCTILE IRON PIPES AND FITTINGS SHALL BE PAINTED "BLUE" AS SPECIFIED. PAINT SPECIFICATIONS MUST BE SUBMITTED TO THE DISTRICT PRIOR TO APPLICATION.



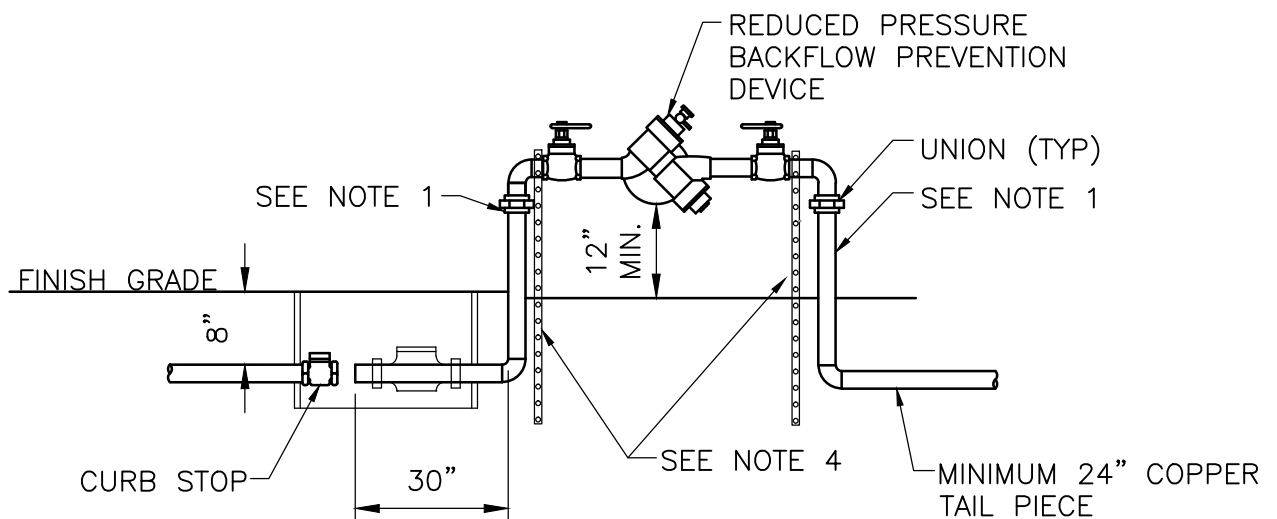
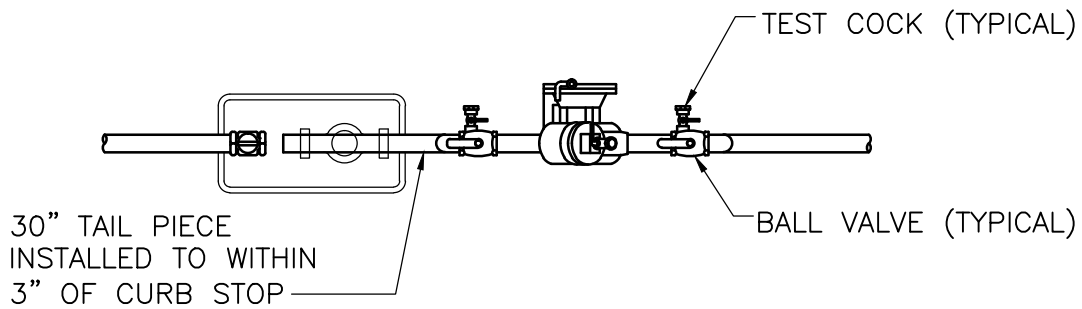

NOTES:

1. BOTH RISERS SHALL BE TYPE "K" COPPER TUBING (HARD DRAWN) WITH COPPER/BRASS SOLDER FITTINGS AND ADAPTERS. ONLY LEAD FREE SOLDER AND FLUX SHALL BE PERMITTED.
2. BACKFLOW PREVENTION DEVICES SHALL BE USC APPROVED WITH SILICONE RUBBER SEAL RINGS OR DISKS:
3. BACKFLOW PREVENTION DEVICE SHALL BE SUPPORTED AT BOTH RISERS WITH STAINLESS STEEL UNISTRUT. RISERS TO BE SECURED TO UNISTRUT WITH 304 STAINLESS STEEL MOUNTING HARDWARE AND ¼" NEOPRENE INSULATORS BETWEEN ALL DISSIMILAR METALS.
4. BACKFLOW DEVICES SHALL BE A MINIMUM OF 3' FROM BACK OF CURB AND SIDEWALKS

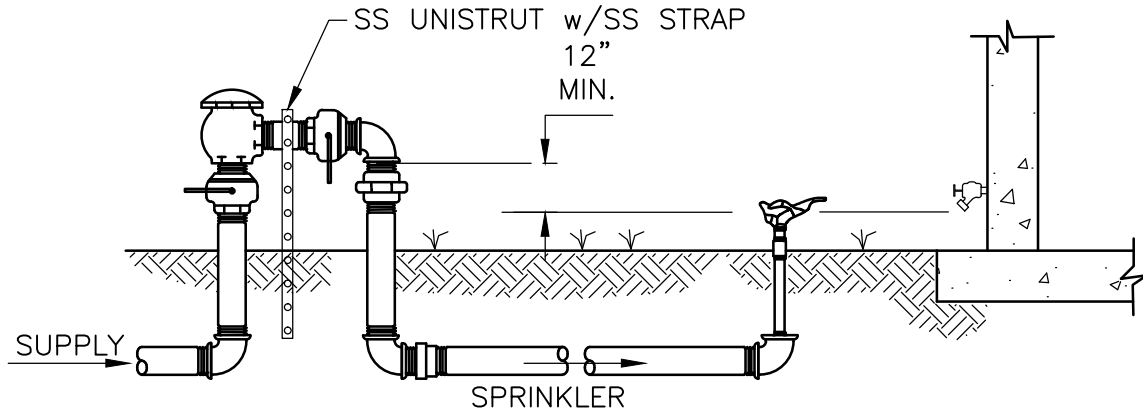

NOTES:

1. THE PRESSURE VACUUM BREAKER (P.V.B.) CANNOT BE INSTALLED WHERE IT WILL BE SUBJECTED TO BACK PRESSURE. IT PROVIDES PROTECTION AGAINST BACK-SIPHONAGE OF BOTH POLLUTANTS AND CONTAMINANTS.
2. EACH P.V.B. SHALL BE INSTALLED IN AN ACCESSIBLE LOCATION TO FACILITATE INSPECTION AND SERVICING.
3. EACH P.V.B. SHALL BE INSTALLED ON THE MAIN LINE TO THE IRRIGATION SYSTEM AND AT LEAST 12 INCHES ABOVE THE HIGHEST SPRINKLER HEAD OR OUTLET. (VALVES MAY BE LOCATED DOWNSTREAM FROM THE DEVICE).
4. ALL ABOVE GROUND PIPING WILL BE TYPE "K" OR "L" COPPER TUBING WITH SWEAT FITTINGS.
5. IF CHEM FEED IS USED IN IRRIGATION LINE, THEN USE RPZ. RPZ MAY BE USED IN LIEU OF PRESSURE VACUUM BREAKER.

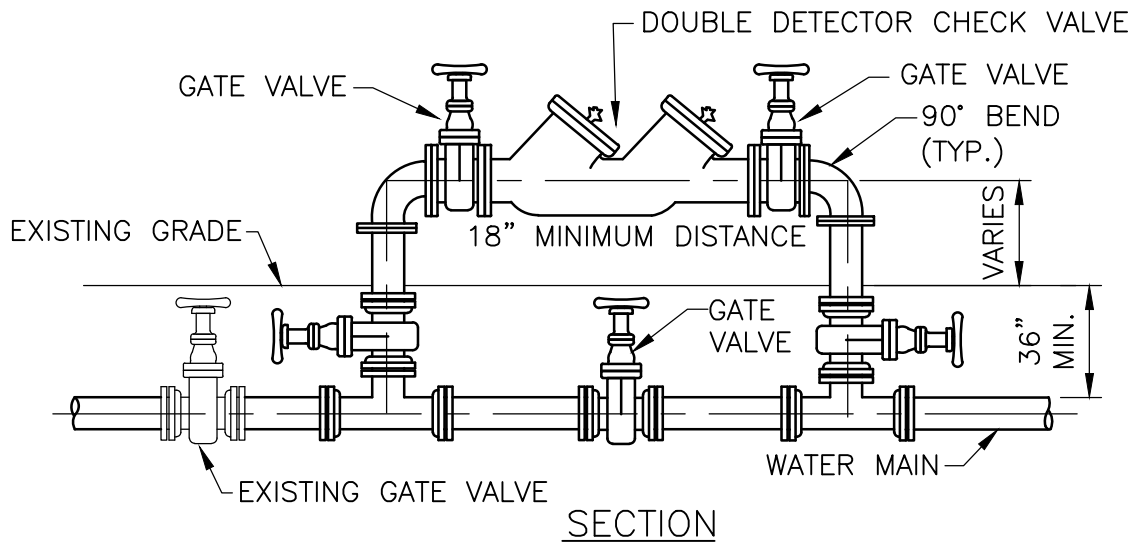

**NOTES:**

1. A TEMPORARY JUMPER CONNECTION IS REQUIRED AT ALL CONNECTIONS BETWEEN EXISTING ACTIVE WATER MAIN AND THE PROPOSED WATER MAIN IMPROVEMENTS.
2. THIS DETAIL IS TO BE USED FOR FILLING NEW WATER MAINS OF ANY SIZE FROM EXISTING ACTIVE WATER MAINS AND FOR FLUSHING OF NEW MAINS UP TO 8" IN DIAMETER AND PULLING BACTERIOLOGICAL SAMPLES FROM ANY NEW WATER MAIN OF ANY SIZE.
3. THE JUMPER CONNECTION SHALL BE MAINTAINED UNTIL AFTER FILLING, FLUSHING, TESTING AND DISINFECTION OF THE NEW WATER MAIN HAS BEEN SUCCESSFULLY COMPLETED AND CLEARANCE FOR USE HAS BEEN RECEIVED FROM THE FLORIDA DEPT. OF ENVIRONMENTAL PROTECTION (FDEP) AND ANY OTHER PERTINENT AGENCIES.
4. ADEQUATE THRUST BLOCKING AND/OR RESTRAINTS SHALL BE TEMPORARILY PROVIDED AS REQUIRED.
5. PIPE AND FITTINGS USED FOR CONNECTING THE PIPE TO THE EXISTING PIPE SHALL BE DISINFECTED PRIOR TO INSTALLATION IN ACCORDANCE WITH AWWA C651, LATEST EDITION.
6. THE CONTRACTOR SHALL PROVIDE DOCUMENTATION DEMONSTRATING THAT THE DOUBLE DETECTOR CHECK BACKFLOW DEVICE HAS BEEN TESTED AND IS IN GOOD WORKING ORDER AT THE TIME OF INSTALLATION.
7. EXCEPT AS REQUIRED TO FLUSH LINES GREATER THAN 8" IN DIA., THE TIE IN VALVE SHALL REMAIN CLOSED AND SHALL BE LOCKED IN THE CLOSED POSITION BY THE DISTRICT. THE TIE IN VALVE SHALL REMAIN CLOSED & LOCKED UNTIL THE NEW SYSTEM HAS BEEN CLEARED BY FDEP.

TEMPORARY JUMPER SCHEDULE

MAIN SIZE	MINIMUM JUMPER SIZE
4"	* 2"
6"	4"
8"	6"
8" or LARGER	6"

**NOTES:** \*1. WITH THE USE OF A 2" JUMPER, A CORP STOP WITH SERVICE SADDLE MAY BE UTILIZED IN LIEU OF A TEE AND VALVE AT MAIN CONNECTION. (SEE DRAWING NO. W-18)

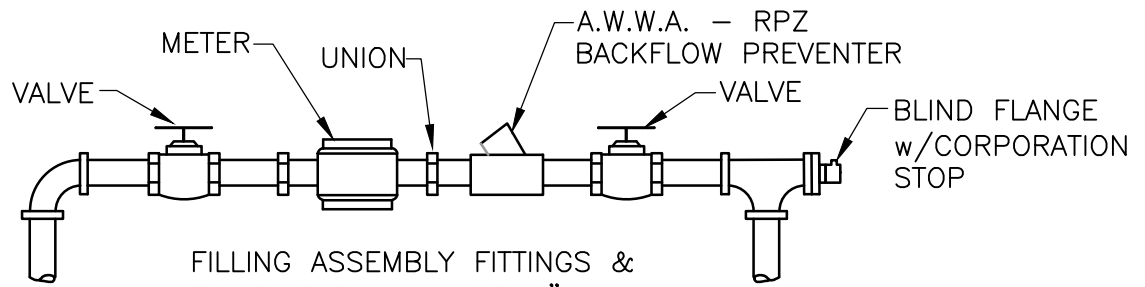

DETAIL "A"

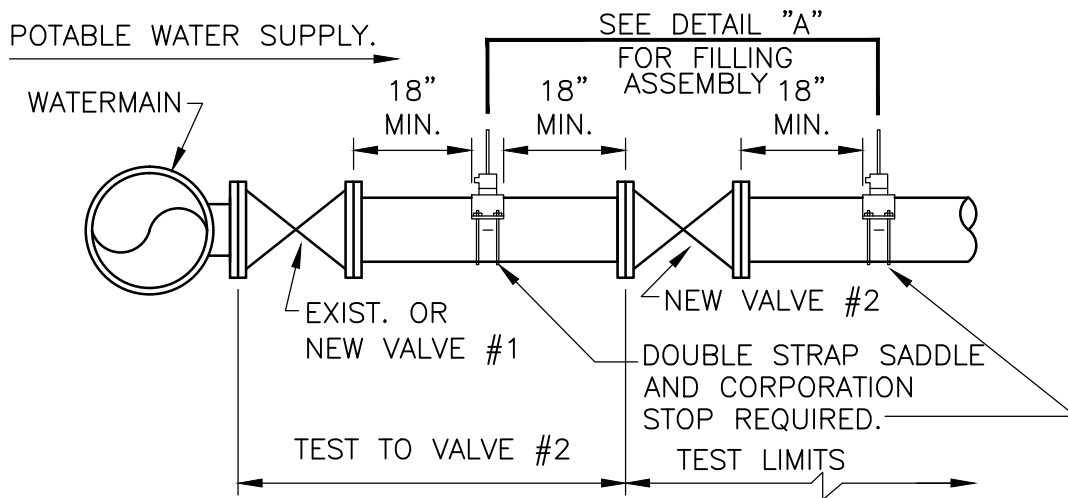

NOTES:

1. BOTH VALVES SHALL BE KEPT CLOSED EXCEPT FOR FILLING, FLUSHING, AND BACTERIOLOGICAL TESTING PURPOSES.
2. THE DISTRICT SHALL BE NOTIFIED BEFORE FILLING AND FLUSHING.
3. AFTER BACTERIOLOGICAL CLEARANCE, SECOND VALVE IS TO BE LEFT OPEN WITHOUT VALVE BOX.
4. PRESSURE TEST PUMP CONNECTS TO SERVICE LINE OR BLOWOFF. NO EXTRA TAPS ARE PERMITTED UNLESS PRECEEDING ARE NOT PRESENT IN TEST SECTION.
5. PRESSURE GAUGE TO BE LOCATED IN VICINITY OF TEST PUMP CONNECTION.
6. GAUGE AND RISER TO BE REMOVED AFTER PRESSURE TEST.
7. REMOVE TEMPORARY CONNECTION AT CORPORATION STOPS AFTER FILLING & FLUSHING HAS BEEN COMPLETED.
8. NEW VALVE MAY BE REMOVED AT DISTRICT'S OPTION.
9. INJECT CHLORINE ON PROJECT SIDE OF BACKFLOW PREVENTER.
10. CONTRACTOR TO PROVIDE AN RPZ CERTIFICATION (LESS THAN 1 YEAR) PRIOR TO INSTALLATION AND CERTIFY THE RPZ EACH ANNIVERSARY DATE OF INSTALLATION WHILE THE WORK IS ONGOING.

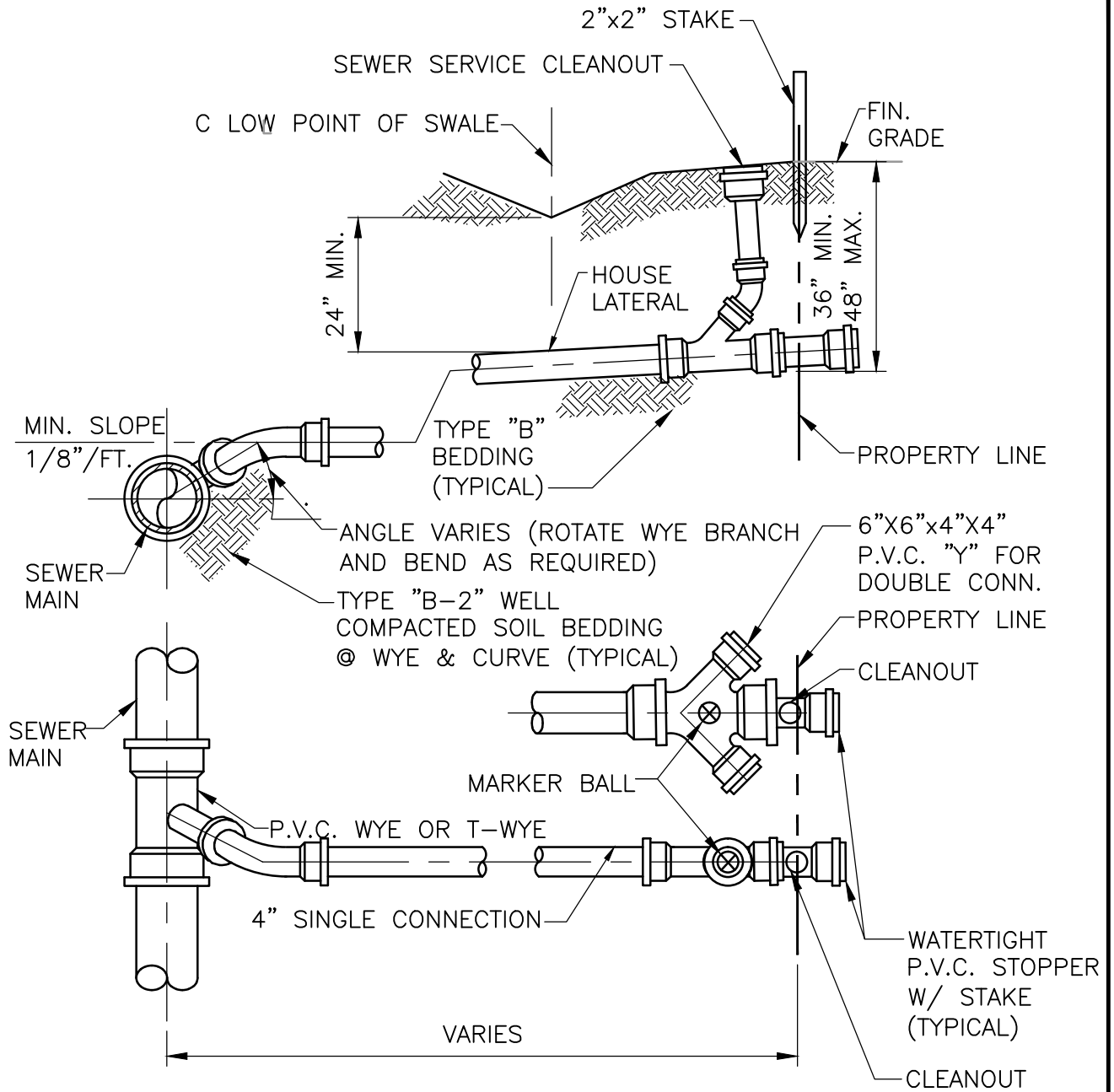

**NOTES:**

1. INVERT OF LATERAL TO BE 36" FROM FINISHED GRADE EXCEPT ON " WATER 1. LINE SIDE " OF STREET R/W WHERE IT SHALL DROP TO 48" AS SOON AS DEPTH OF SEWER MAIN PERMITS.
2. INSTALL MAGNETIC MARKERS AT THE END OF EACH SERVICE LINE OR OPPOSITE WYES AND RECORD LOCATION.



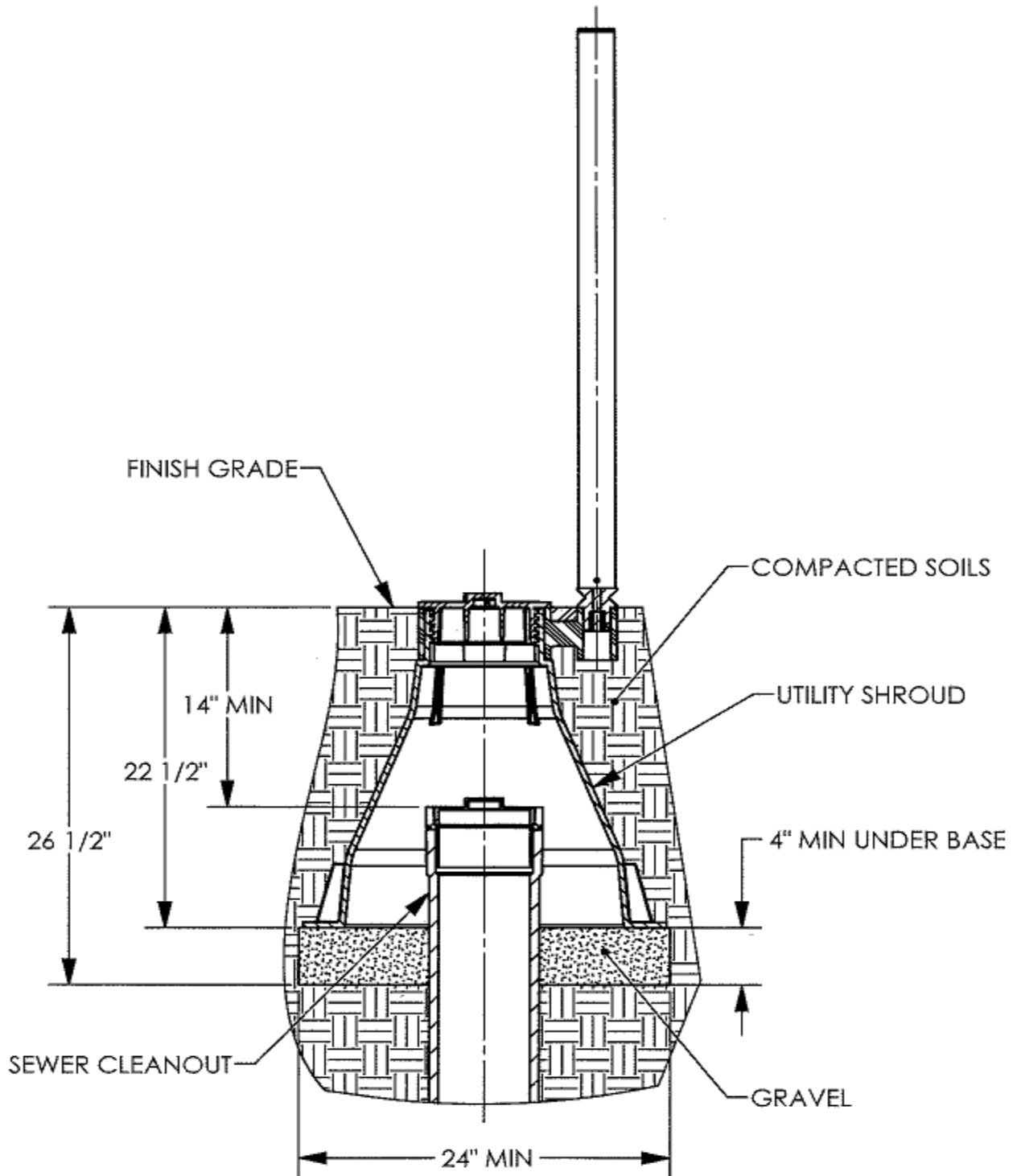

ST. LUCIE COUNTY  
 WATER & WASTEWATER  
 CONSTRUCTION  
 STANDARDS

SHROUD FOR  
 SEWER CLEANOUT ASSEMBLY

APPROVED: DECEMBER 2019

DRAWING NUMBER: S-2B

RAISED LETTERS (ST. LUCIE COUNTY UTILITIES) 1" HIGH, FLUSH WITH TOP OF COVER

CAST IRON FRAME AND COVER U.S. FOUNDRY TYPE 227-AS OR APPROVED EQUAL

RAISED LETTERS (2015) 1" HIGH FLUSH WITH TOP OF COVER UPDATE TO YEAR OF CASTING

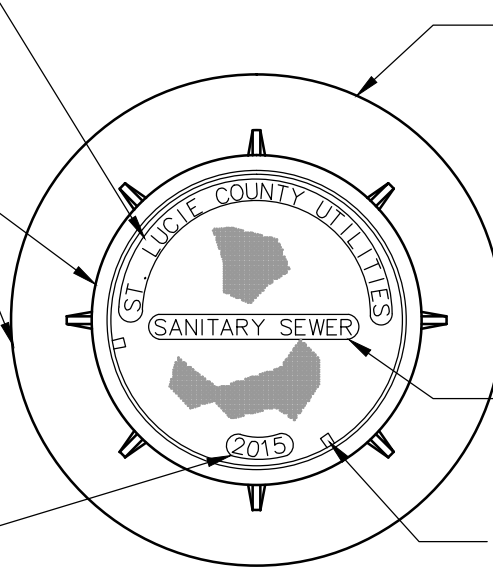

FRAME AND COVER SHALL BE MACHINED OR GROUND TO SEAT FIRMLY AND PREVENT ROCKING

RAISED LETTERS (SANITARY SEWER) 1" HIGH FLUSH WITH TOP OF COVER

(2) NON PENETRATING PICK HOLES REQUIRED

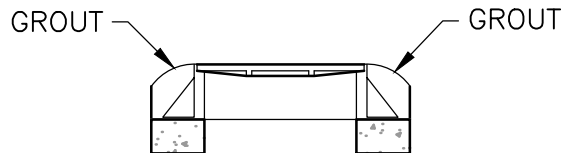

NOTES:

1. MINIMUM WEIGHTS: COVER – 190 LBS., FRAME – 220 LBS.
2. FRAME AND COVER SHALL BE U.S. FOUNDRY 227-AS OR APPROVED EQUAL.
3. MANHOLE COVER SHALL HAVE THE WORDS "ST. LUCIE COUNTY UTILITIES" "SANITARY SEWER", AND THE YEAR OF THE CASTING CAST IN METAL. LETTERING SHALL BE 1" HIGH AND FLUSH W/ TOP OF COVER.
4. MANHOLE COVER SHALL MEET H-20 TRAFFIC LOADING.



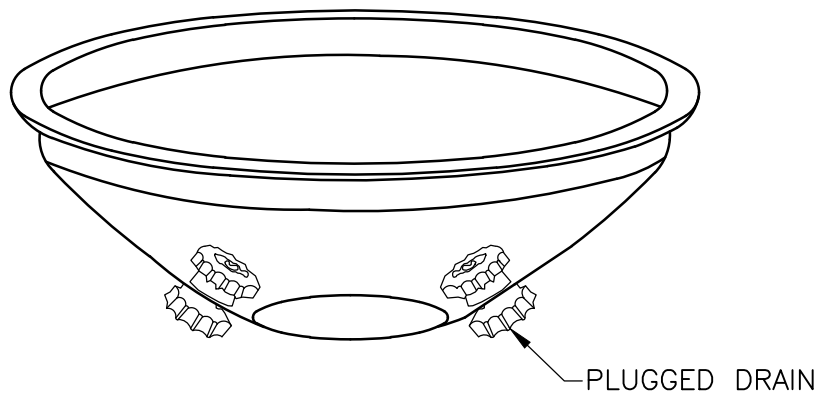

NOTES:

1. RAIN GUARDS SHALL BE INSTALLED ON ALL MANHOLES, REQUIRED BY THE DISTRICT.

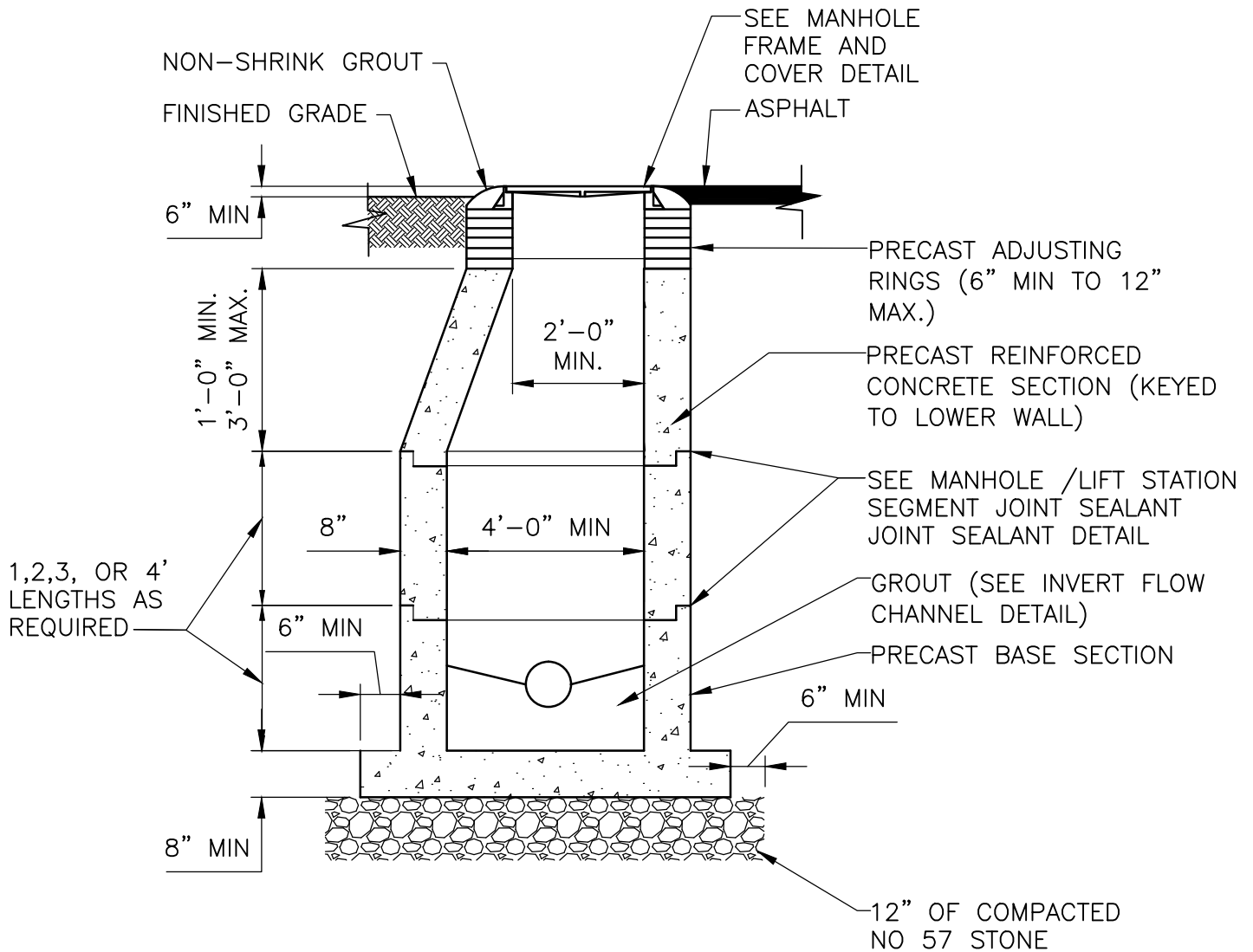

NOTES:

1. MANHOLES SHALL BE DESIGNED IN ACCORDANCE WITH ASTM C478.
2. CONNECTIONS AND GROUTING IN MANHOLE NOT SHOWN. SEE DRAWINGS FOR PIPE SIZE, LOCATIONS AND INVERTS.
3. PAINT OUTSIDE OF MANHOLE WITH TWO COATS OF COAL TAR EPOXY (BITUMASTIC 50)
4. LINE INSIDE OF MANHOLE WITH AN APPROVED LINING MATERIAL.
5. ALL PIPE PENETRATIONS SHALL BE PRECAST.

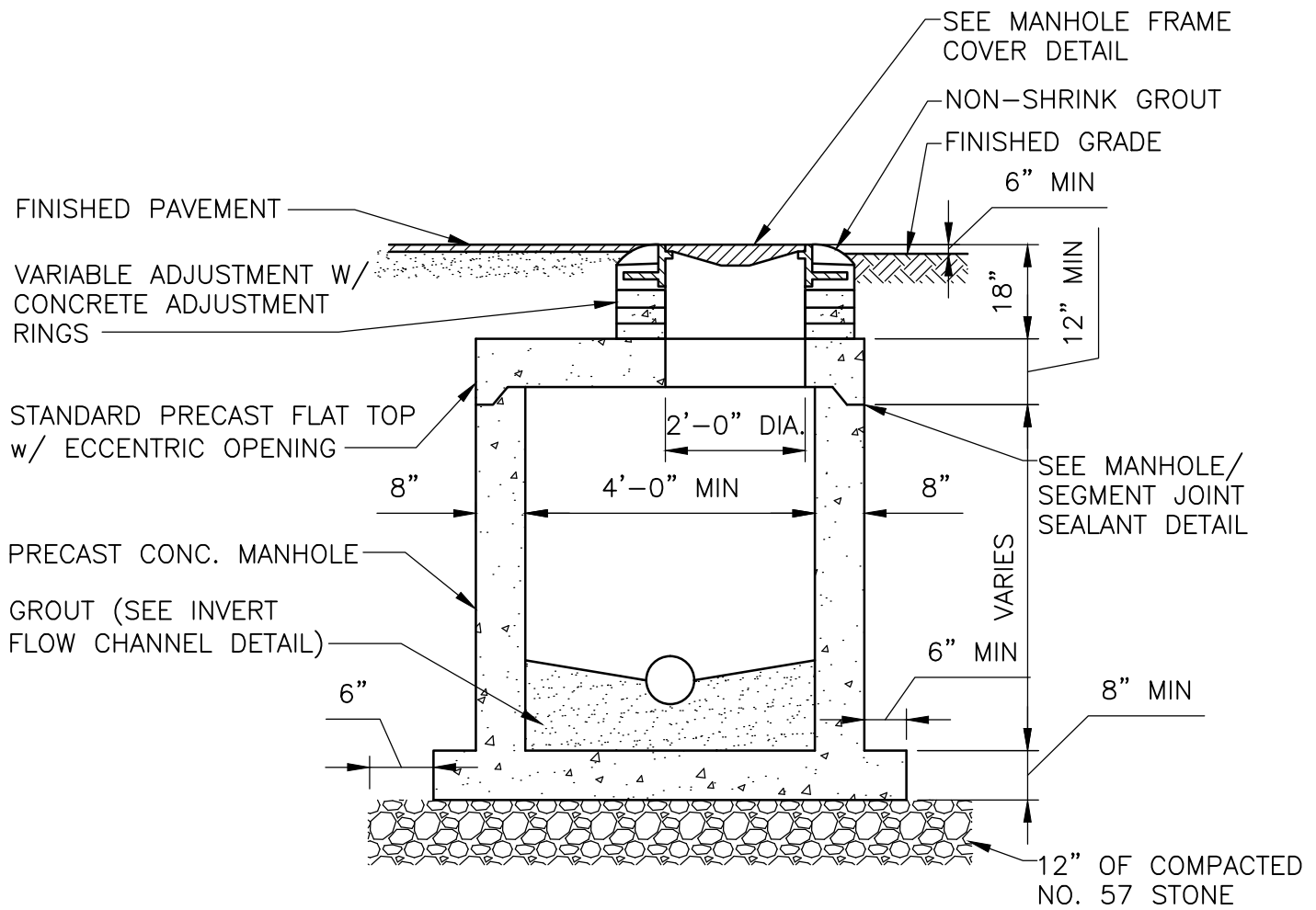

NOTES:

1. MANHOLES SHALL BE DESIGNED IN ACCORDANCE WITH ASTM C478.
2. CONNECTIONS AND GROUTING IN MANHOLE NOT SHOWN. SEE DRAWINGS FOR PIPE SIZE, LOCATIONS AND INVERTS.
3. PAINT OUTSIDE OF MANHOLE WITH TWO COATS OF COAL TAR EPOXY (BITUMASTIC 50)
4. LINE INSIDE OF MANHOLE WITH AN APPROVED LINING MATERIAL.
5. ALL PIPE PENETRATIONS SHALL BE PRECAST.
6. THIS TYPE OF MANHOLE SHALL BE LIMITED TO DEPTHS OF 6 FEET.

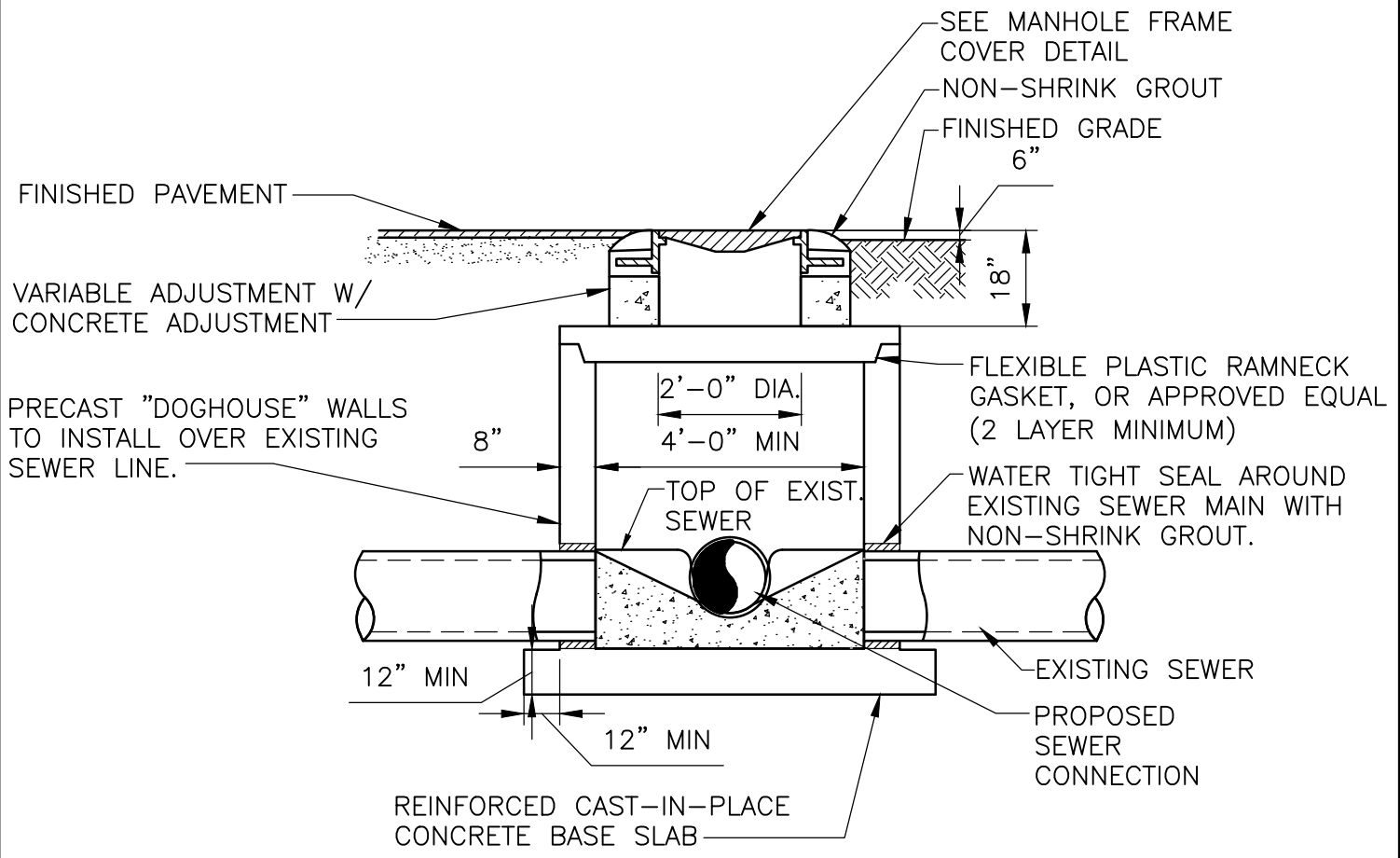

**NOTES:**

1. MANHOLES SHALL BE DESIGNED IN ACCORDANCE WITH ASTM C478.
2. CONNECTIONS AND GROUTING IN MANHOLE NOT SHOWN. SEE DRAWINGS FOR PIPE SIZE, LOCATIONS AND INVERTS.
3. PAINT OUTSIDE OF MANHOLE WITH TWO COATS OF COAL TAR EPOXY (BITUMASTIC 50)
4. LINE INSIDE OF MANHOLE WITH AN APPROVED LINING MATERIAL.
5. BREAK OUT TOP OF EXISTING SEWER PIPE AFTER MANHOLE INSTALLATION. GROUT FLOW CHANNELS IN ACCORDANCE WITH INVERT FLOW CHANNEL DETAIL.
6. EXISTING SEWER FLOW SHALL BE MAINTAINED DURING CONSTRUCTION.

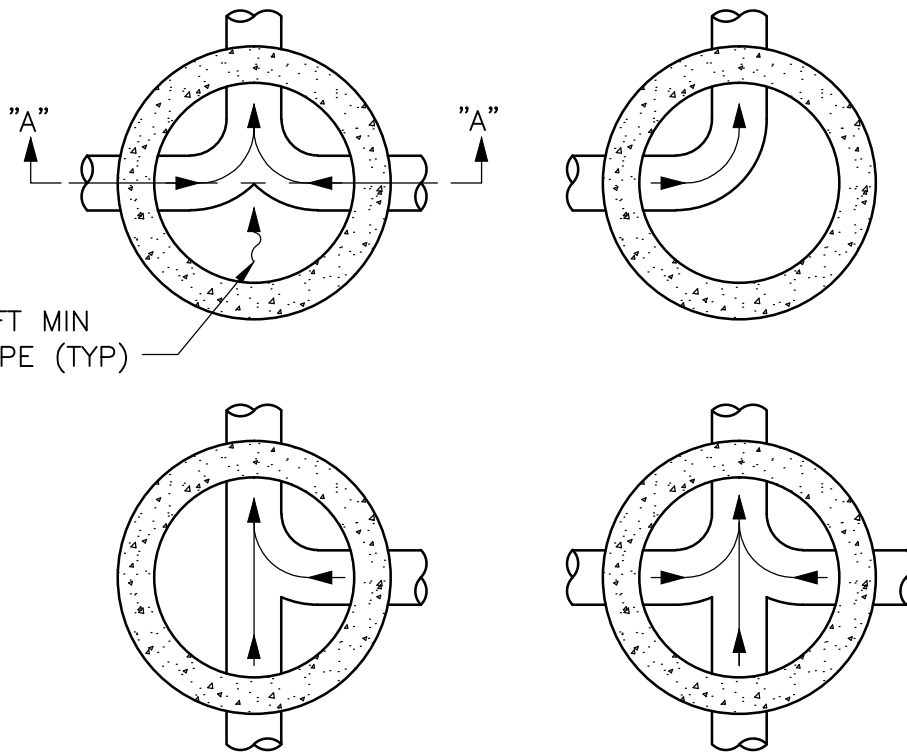

1/2" PER FT MIN  
BENCH SLOPE (TYP)

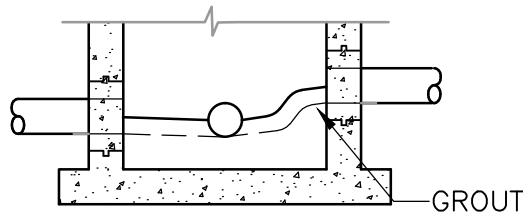

SECTION "A-A"

NOTES:

1. ALL INVERT CHANNELS ARE TO BE CONSTRUCTED FOR SMOOTH FLOW WITHOUT OBSTRUCTION.
2. TROWEL SLOPE AND CHANNELS SMOOTH TO PREVENT COLLECTION OF MATERIALS.
3. SIDEWALLS OF FLOW CHANNEL SHALL BE AT LEAST HALF OF PIPE HEIGHT AT ALL POINTS.

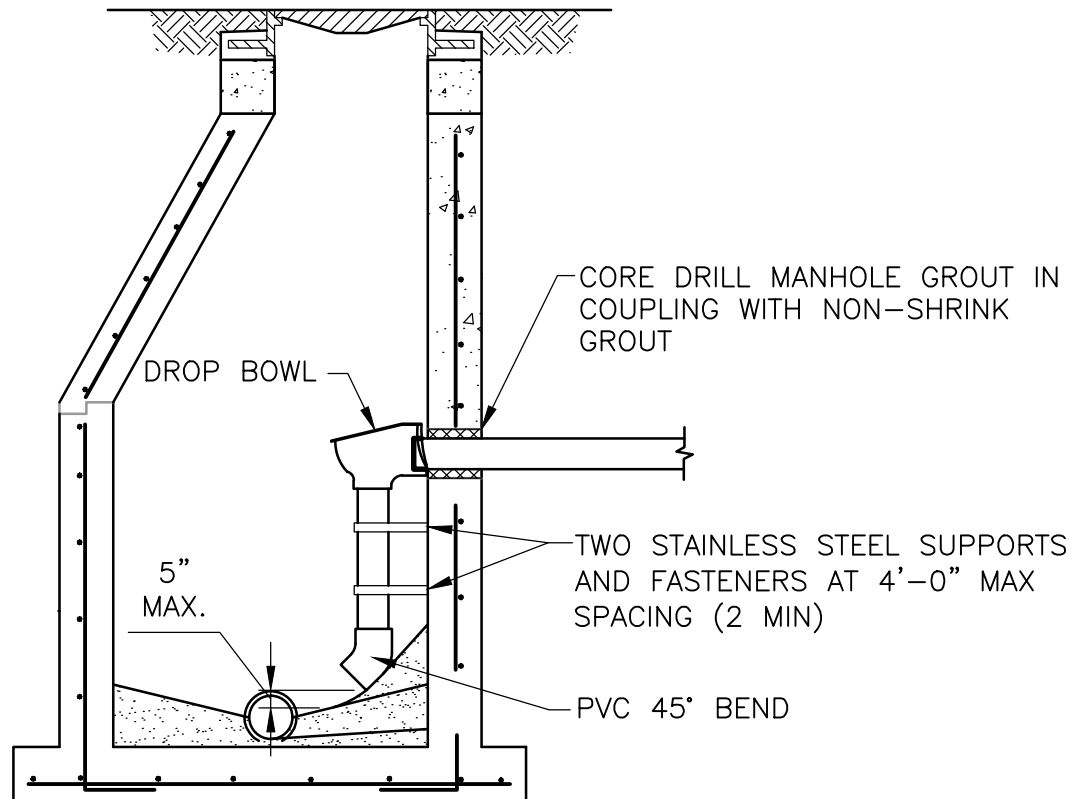

NOTES:

1. ALL DETAILS AND SPECIFICATIONS FOR STANDARD MANHOLES ARE APPLICABLE EXCEPT FOR REFERENCES TO DROP ASSEMBLY AND COATINGS.
2. THE PRECAST BASE SHALL EXTEND FULLY UNDER THE DROP ASSEMBLY.
3. DROP CONNECTIONS SHALL BE REQUIRED WHENEVER AN INFLUENT INVERT IS LOCATED 2.0 FEET OR MORE ABOVE THE MAIN INVERT CHANNEL. DROP CONNECTIONS SHOULD NOT BE DESIGNED FOR LESS THAN A 24-INCH DROP.
4. SOLVENT TYPE JOINT P.V.C. FITTINGS MAY BE UTILIZED IN THE DROP ASSEMBLY ONLY.

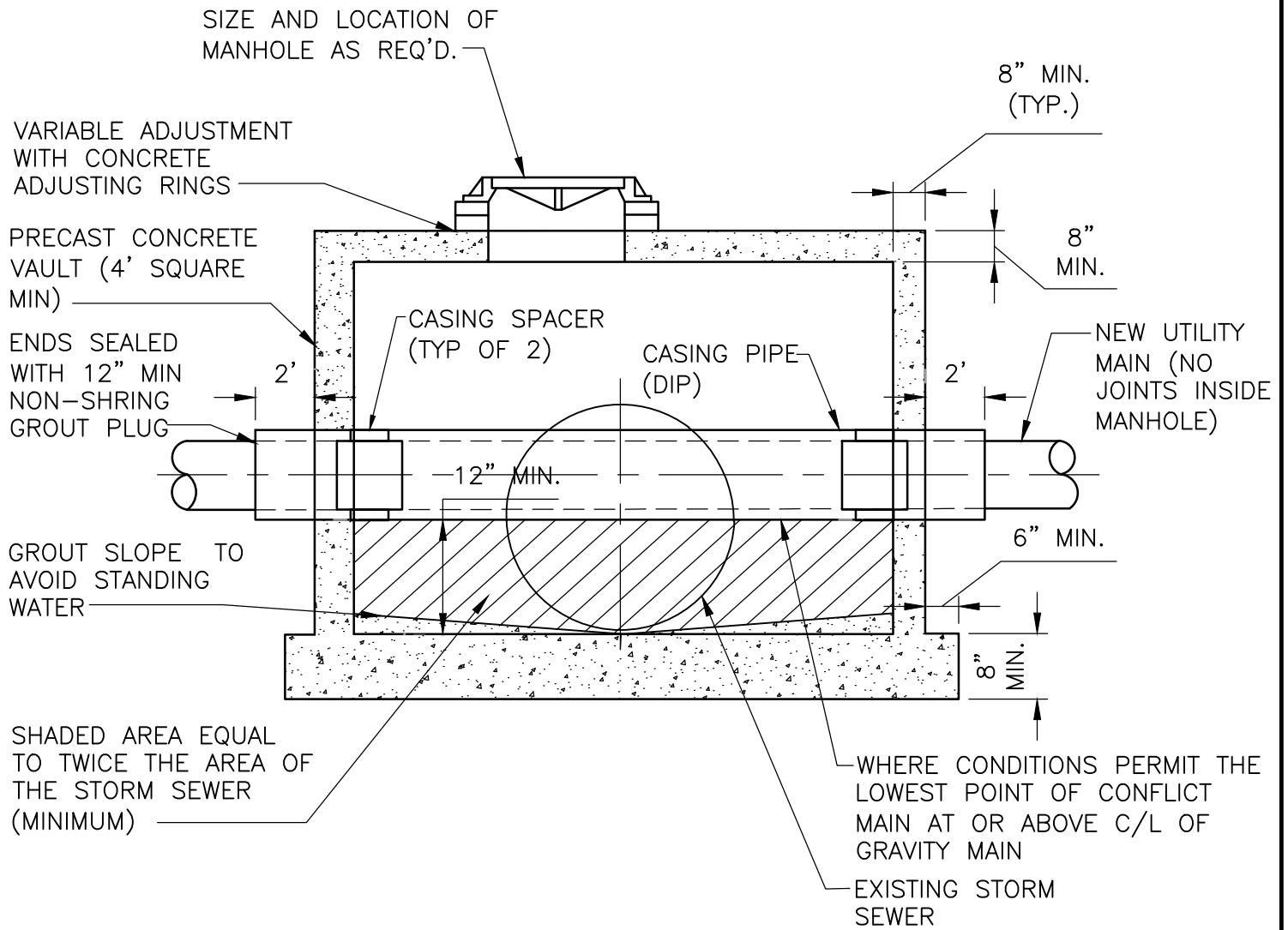

**NOTES:**

1. CONFLICT MANHOLES WILL BE ALLOWED WHERE DESIGN PROBLEMS PROVE IT TO BE THE ONLY VIABLE SOLUTION AND MUST BE APPROVED BY THE DISTRICT.
2. PRECAST VAULT SHALL BE DESIGNED IN ACCORDANCE WITH ASTM C478.



ST. LUCIE COUNTY  
WATER & WASTEWATER  
CONSTRUCTION  
STANDARDS

CONFLICT MANHOLE  
DETAIL

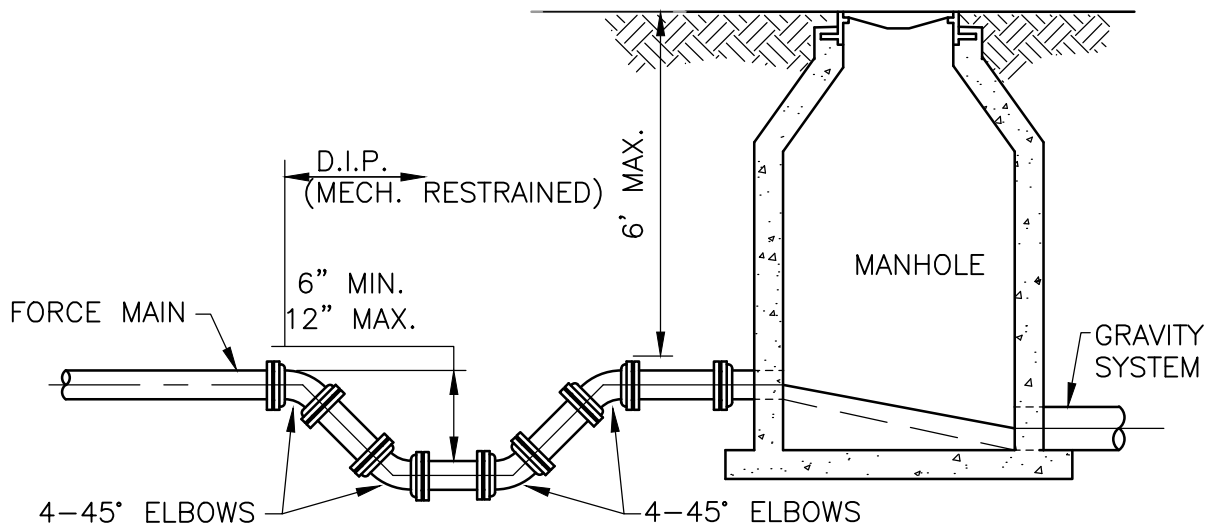

NOTES:

1. FORCE MAIN TO ENTER MANHOLE AS CLOSE AS POSSIBLE TO 180° TO GRAVITY OUTLET.
2. THE INVERT LEVEL OF FORCE MAIN AT POINT OF ENTRY SHALL BE 6" ABOVE INVERT OF MANHOLE.
3. CORE ENTRY ONLY INTO EXISTING MANHOLES.
4. TRAP TO BE LOCATED PRIOR TO DROP INTO MANHOLE AND OUTSIDE OF PAVED AREAS.
5. USE TWO 45° ELBOWS PAST TRAP IF ELEVATION DROP IS REQUIRED TO ENTER MANHOLE.
6. FLOW CHANNEL REQUIRED.
7. EXTERIOR OF MANHOLE TO RECEIVE 2 COATS OF COAL TAR EPOXY (BITUMASTIC 50). INTERIOR OF MANHOLE TO BE LINED WITH APPROVED LINING MATERIAL.



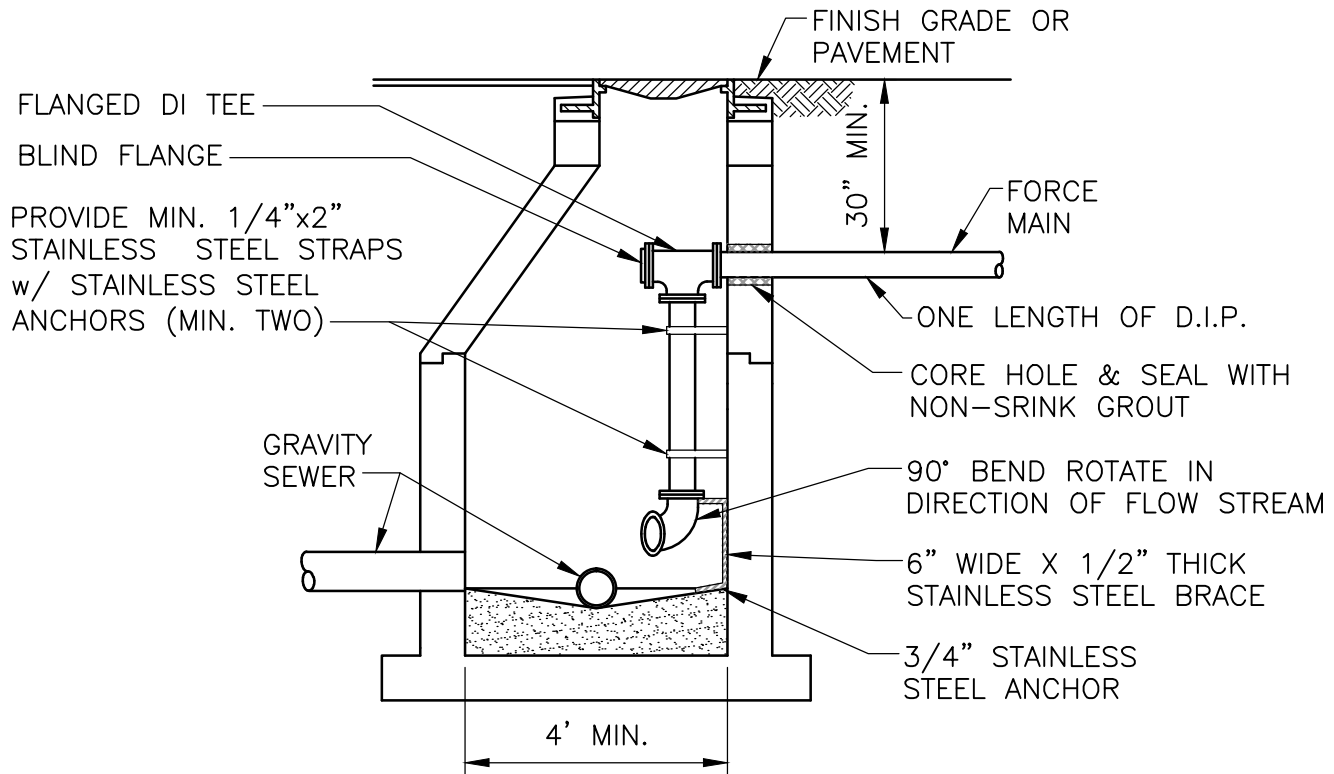

NOTES:

1. DROP PIPE AND 90° BEND SHALL BE SCH 80 PVC.
2. DI PIPE AND FITTINGS INSIDE THE MANHOLE SHALL BE COATED WITH AN APPROVED SYSTEM FOR EXPOSED METAL INSIDE MANHOLES AND LIFT STATIONS
3. ALL OPENINGS SHALL BE SEALED WITH A WATERPROOF NON-SHRINKING GROUT.
4. FLOW CHANNELS SHALL BE CONSTRUCTED TO DIRECT INFLUENT INTO FLOW STREAM. (SEE DETAIL)
5. EXTERIOR OF MANHOLE TO RECEIVE 2 COATS OF COAL TAR EPOXY (BITUMASTIC 50). INTERIOR OF MANHOLE TO BE LINED WITH APPROVED LINING MATERIAL.

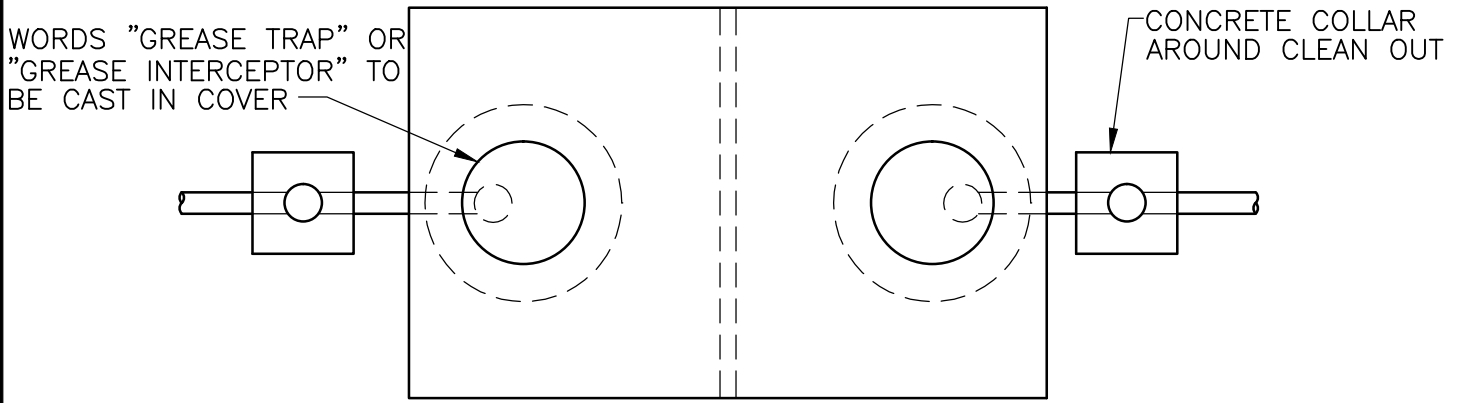

TOP VIEW

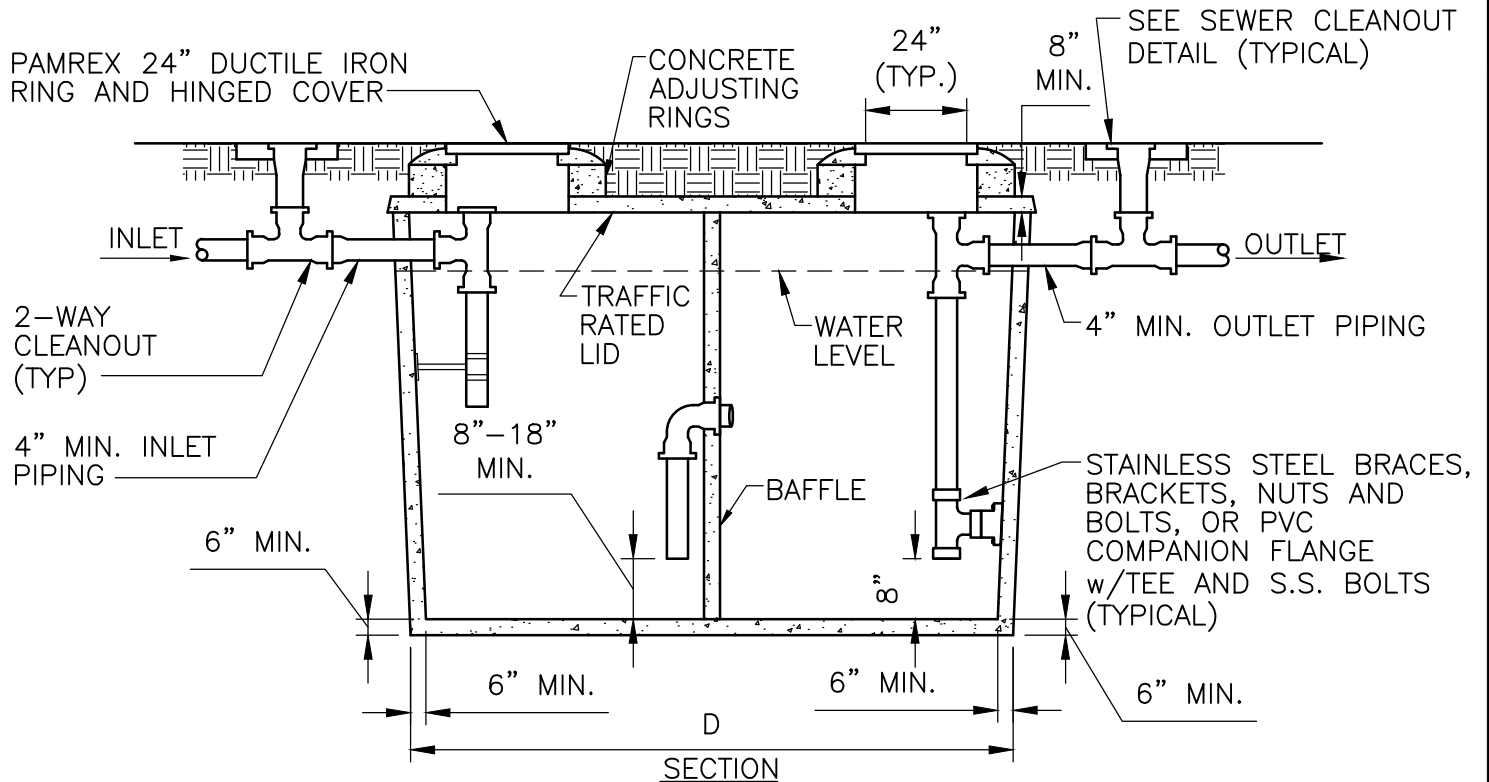

SECTION

**NOTES:**

1. GREASE TRAPS (SEPTIC TANKS) SHALL BE MANUFACTURED BY FLORIDA SEPTIC INC., SEBRING SEPTIC, AVERETT SEPTIC, OR APPROVED EQUAL STATEMENT:  
"THIS CONCRETE STRUCTURE MEETS OR EXCEEDS ALL THE REQUIREMENTS FOR GREASE INTERCEPTORS/SEPTIC TANKS AS IN THE FLORIDA ADMINISTRATIVE CODE, CHAPTERS 64E-6.0138D & THE SHOP DRAWINGS (3 COPIES MINIMUM) SHALL THEN BE SIGNED AND SEALED BY THE ENGINEER-OF-RECORD AND FORWARDED TO THE DISTRICT FOR APPROVAL."
2. ALL INTERNAL COMPONENTS WILL BE CONSTRUCTED BY GREASE TRAP INSTALLER.
3. TANK INSPECTIONS WILL OCCUR WITH TANK ABOVE GROUND.
4. BAFFLE SHALL BE INSTALLED 1/2 (ONE HALF) TO 2/3 (TWO THIRDS) 'D'.
5. MEETS H2O LOAD REQUIREMENTS.



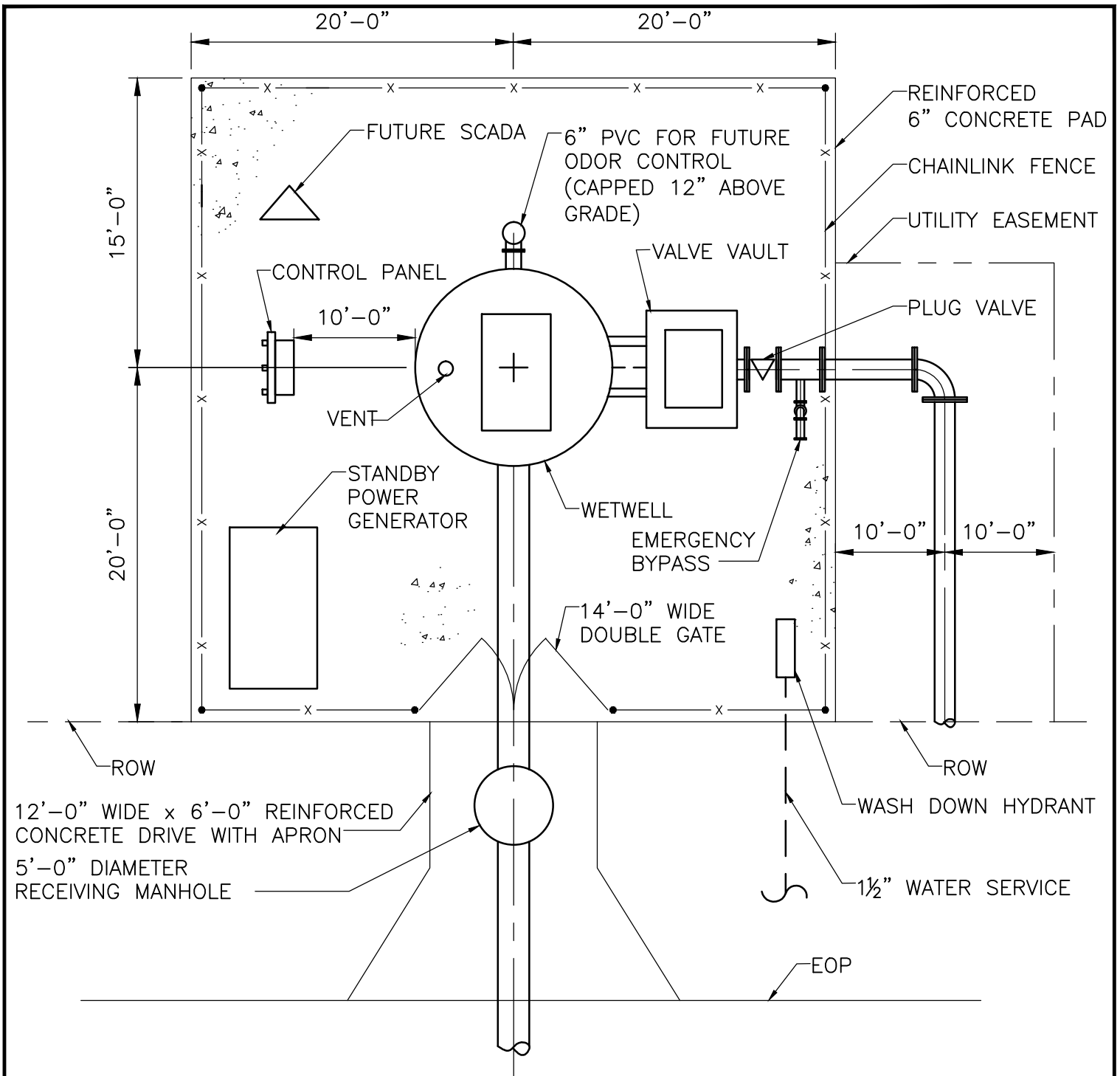

**NOTES:**

1. APPLIES TO LIFT STATIONS SERVING 500 ERCS OR GREATER OR RECEIVING FLOW FROM ONE OR MORE LIFT STATIONS
2. ALTERNATE LIFT STATION LAYOUTS WILL BE CONSIDERED BY THE DISTRICT ON A CASE-BY-CASE BASIS.



ST. LUCIE COUNTY  
WATER & WASTEWATER  
CONSTRUCTION  
STANDARDS

TYPICAL LIFT STATION PLAN  
(LARGE)

DATE APPROVED: DECEMBER 2015      DRAWING NUMBER: S-15

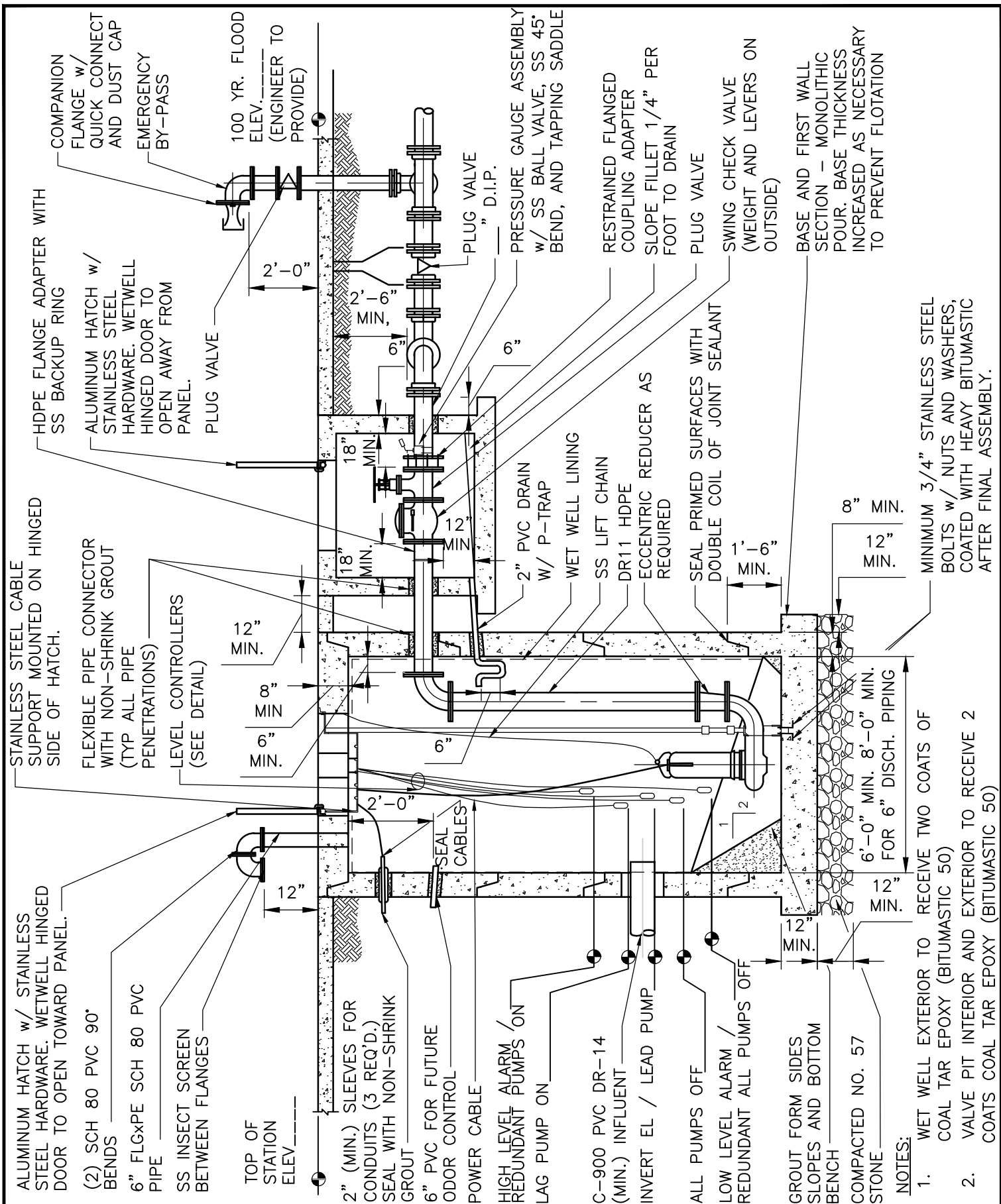

- NOTES:
1. WET WELL EXTERIOR TO RECEIVE TWO COATS OF COAL TAR EPOXY (BITUMASTIC 50)
  2. VALVE PIT INTERIOR AND EXTERIOR TO RECEIVE 2 COATS COAL TAR EPOXY (BITUMASTIC 50)



ST. LUCIE COUNTY  
WATER & WASTEWATER  
CONSTRUCTION  
STANDARDS

TYPICAL LIFT STATION  
(SECTION)

PUMP DATA:

MANUFACTURER, \_\_\_\_\_  
\_\_\_\_\_ MODEL No., \_\_\_\_\_ IMP. No., \_\_\_\_\_ MOTOR,  
\_\_\_\_\_ HP, \_\_\_\_\_ RPM, \_\_\_\_\_ VOLTS, \_\_\_\_\_ PHASE, 60 HERTZ

OPERATING CONDITIONS:

\_\_\_\_\_ GPM AT \_\_\_\_\_ TDH. \_\_\_\_\_ % EFFICIENCY

WET WELL:

SIZED FOR MINIMUM PUMP CYCLE TIME OF 10 MINUTES AND A MAXIMUM  
OF 6 PUMP STARTS PER HOUR ASSUMING NO ALTERNATION OF PUMPS.  
WORKING DEPTH \_\_\_\_\_ FT. WORKING VOLUME \_\_\_\_\_ GALS.

ELECTRICAL:

FEEDERS AND CONDUIT \_\_\_\_\_ MAIN SWITCH \_\_\_\_\_ POLES \_\_\_\_\_ AMPS

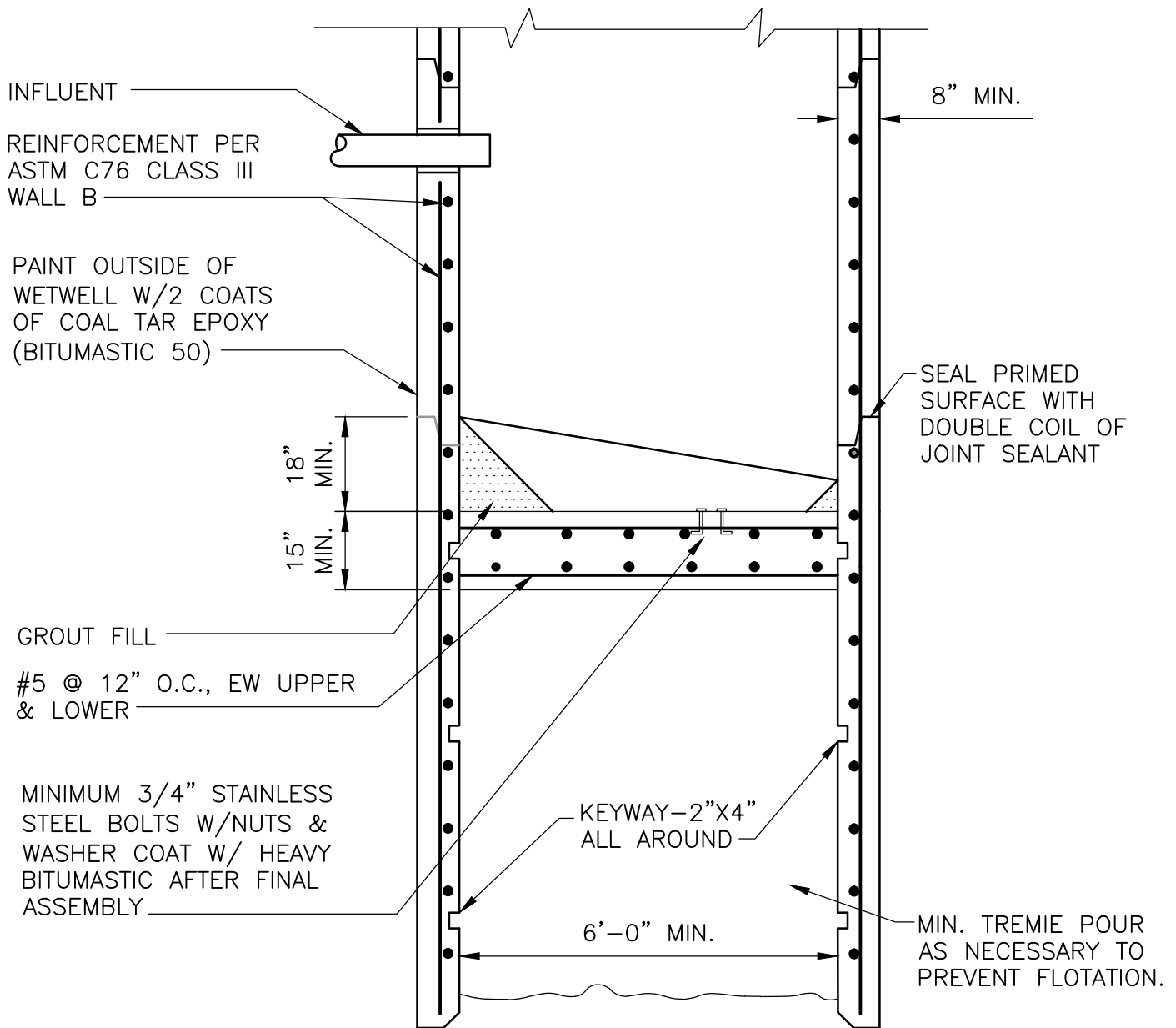

SECTION

NOTES:

1. CONCRETE WETWELL SECTIONS SHALL BE CONNECTED BY STEEL STRAPS, SIX PER JOINT. CONTRACTOR SHALL SUBMIT METHOD TO DISTRICT FOR APPROVAL ALONG WITH SHOP DRAWING.
2. SEE TYPICAL LIFT STATION DETAILS FOR ADDITIONAL DESIGN AND CONSTRUCTION STANDARDS.
3. TREMIE SEAL MINIMUM 5'-0" THICK.
4. DESIGN CALCULATIONS TO BE SUBMITTED FOR APPROVAL.
5. INSIDE OF WET WELL SHALL BE COATED WITH AN APPROVED WETWELL LINING.

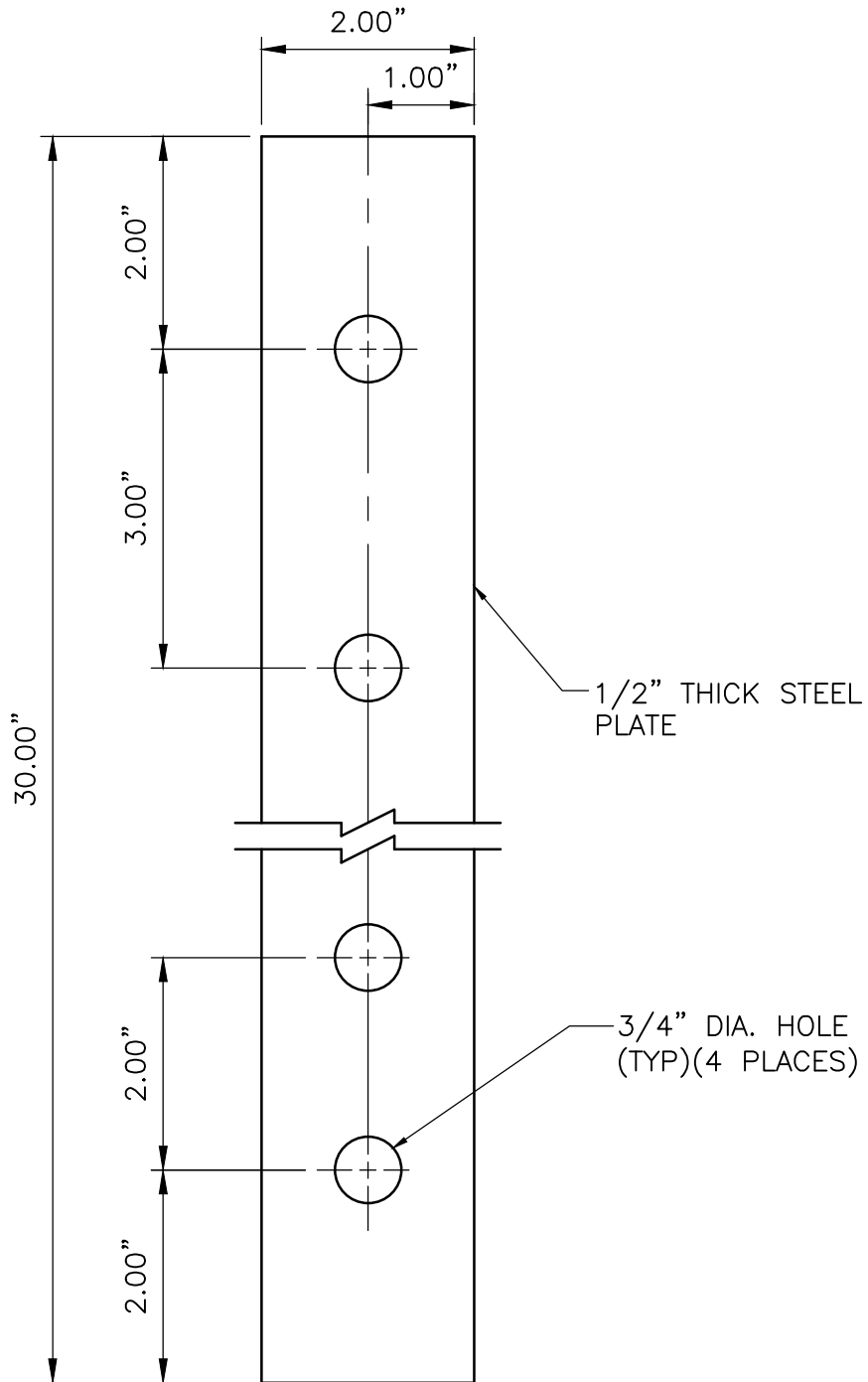

**NOTE:**

1. 6 RETAINER STRAPS REQUIRED PER JOINT.



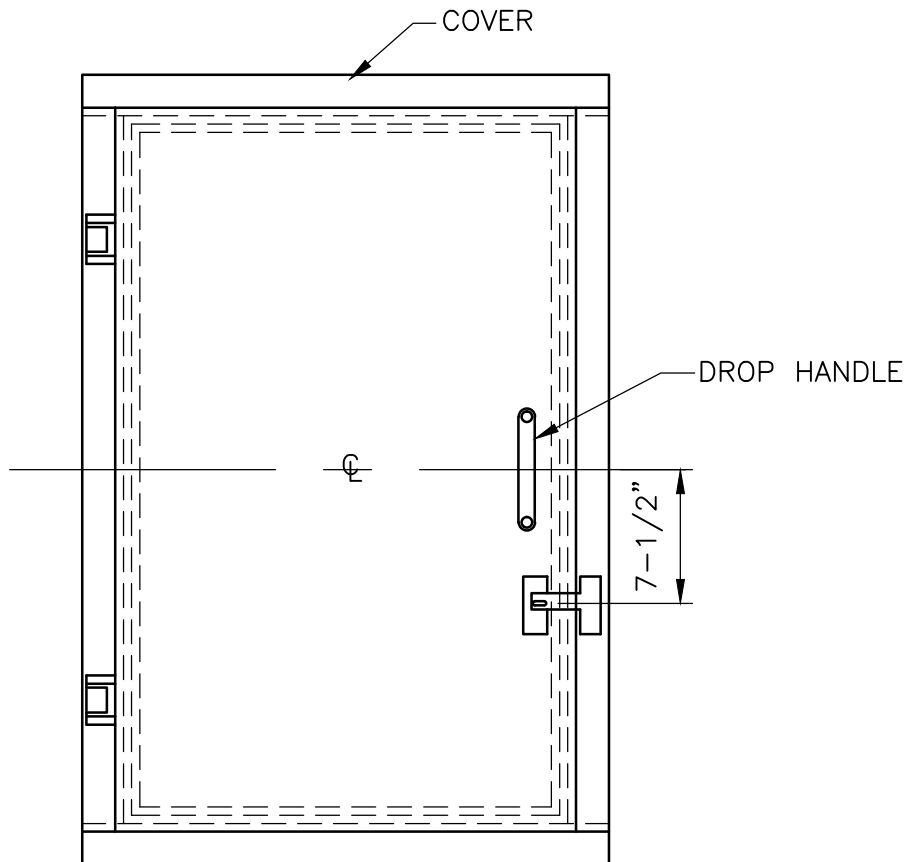

NOTES:

1. COVER TO BE ALUMINUM DIAMOND PLATE, HINGED, TRAFFIC BEARING WITH POSITIVE LOCKING ARM AND LOCKING HASP.
2. COVER SHALL BE SIZED ACCORDING TO PUMP MANUFACTURE'S REQUIREMENTS (30"x48" MIN)
3. COVER SHALL BE CAST IN PLACE.
4. SPLIT COVER IS ACCEPTABLE FOR LARGER SIZES.
5. RECESSED HASP IS REQUIRED IN WALKWAYS AND TRAFFIC AREAS.
6. COVER SHALL BE H-20 LOAD RATED.
7. HINGES AND ALL FASTENING HARDWARE SHALL BE 316 STAINLESS STEEL.
8. LID TO OPEN TOWARD PANEL.
9. ALUMINUM SURFACES IN CONTACT WITH CONCRETE SHALL BE COATED WITH AN APPROVED COATING SYSTEM. 10. DOORS SHALL INCORPORATE ENCLOSED STAINLESS STEEL SPRING ASSISTS.

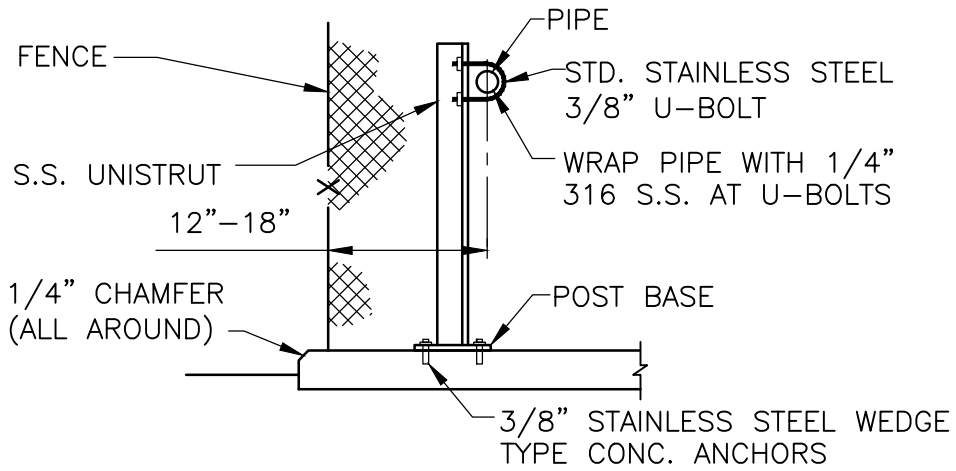
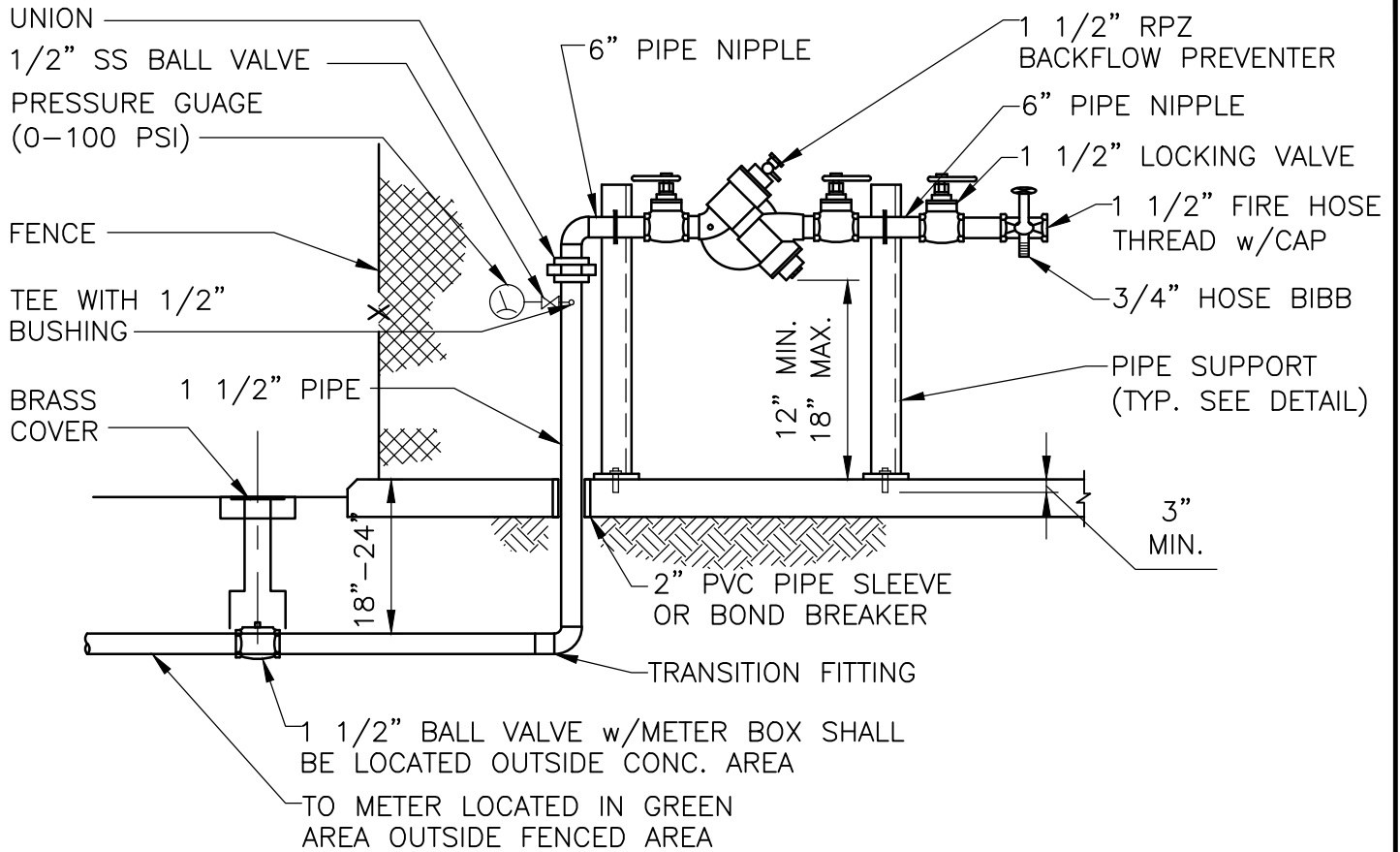

PIPE SUPPORT DETAIL

**NOTES:**

1. ALL ABOVE GRADE PIPING SHALL BE BRASS. FITTINGS SHALL BE BRONZE.
2. ALL JOINTS SHALL BE THREADED.
3. MIN. 24" CLEARANCE BETWEEN RPZ BACKFLOW PREVENTER AND CONTROL PANEL REQUIRED.
4. THREADED AREAS OF CORPORATION STOP AND OTHER FITTINGS SHALL BE SPIRAL WRAPPED WITH TWO WRAPS OF TEFLON TAPE.

PRECAST CONCRETE SUPPORT PLANK, MIN. 4" THICK, MIN. 60" WIDE x 12' LONG w/ #4 REBAR @ 12". 3/4" CHAMFER ON ALL EXPOSED EDGES.

FLASH RED WARNING LIGHT WITH AUDIBLE ALARM

STAINLESS STEEL SERVICE PANEL (DEADFRONT)

GENERATOR RECEPTACLE

S.S. OR ALUM., EXPLOSION PROOF JUNCTION BOX w/CROUSE HINDS OR APPROVED EQUAL. EXPLOSION PROOFED SEALOFFS ON TOP OF BOX.

TO POWER SOURCE

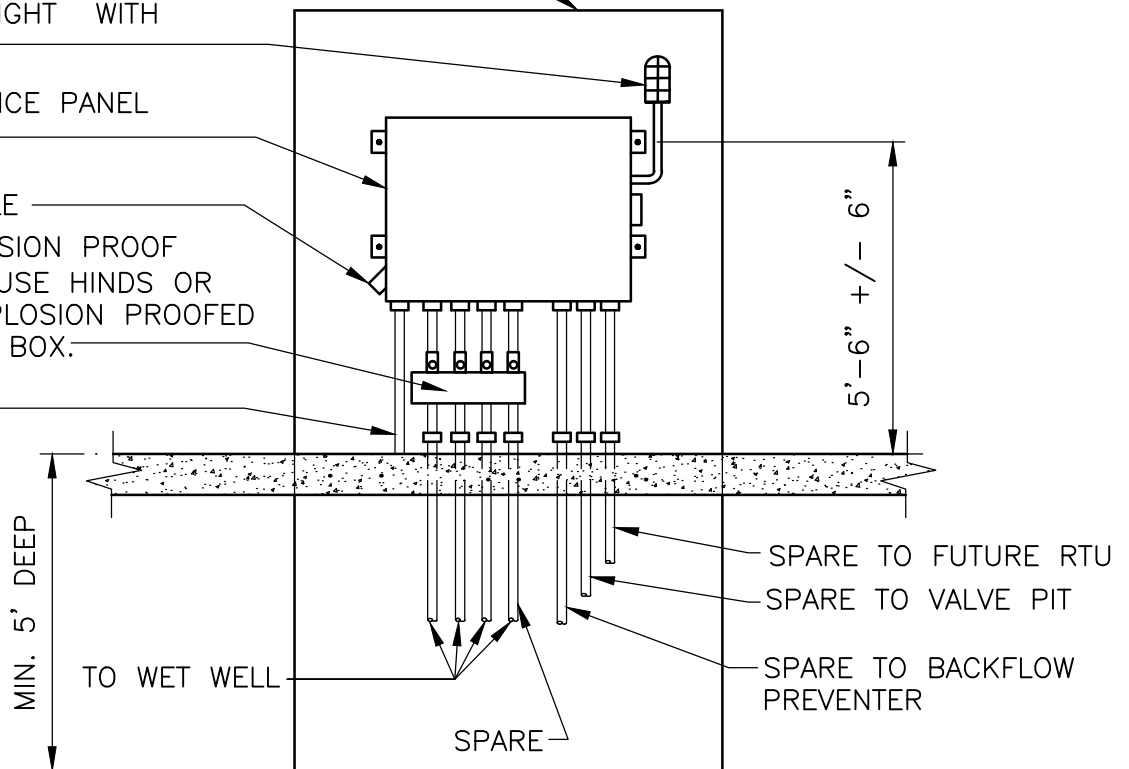

NOTES:

1. ELECTRIC METER AND PRIMARY DISCONNECT MOUNTED ON BACK SIDE OF PANEL.
2. EMERGENCY GENERATOR RECEPTACLES: REQUIRED WHEN PERMANENT GENERATOR NOT PROVIDED.
3. ALL POWER AND CONTROLS LINES SHALL BE CONTINUOUS (NO SPLICES).
4. PANEL MOUNTED TO S/S UNI-STRUT BY WELDED TABS.
5. CONTROL PANEL SHALL BE UL LISTED AS A UNIT.
6. ALL HARDWARE, NUTS & BOLTS, AND APPURTENANCES ABOVE GROUND SHALL BE 316 STAINLESS STEEL.
7. ALL CONDUITS UV RESISTANT SCH 80 PVC
8. PANEL MOUNTING SHALL ALLOW FOR UNRESTRICTED VIEW OF ALARM LIGHT.
9. NO PENETRATIONS THROUGH TOP OF PANEL BOX.

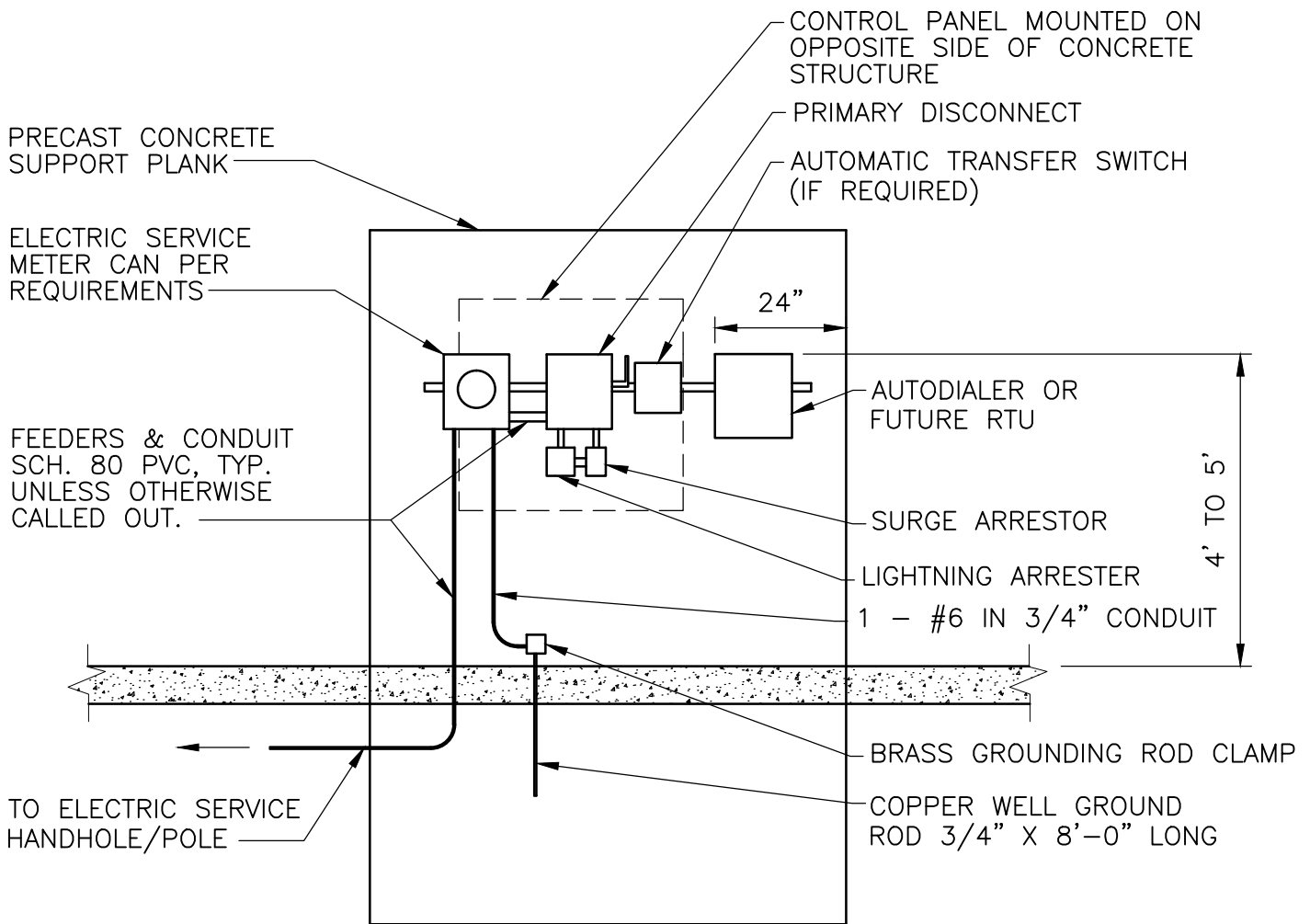

NOTES:

1. NO PENETRATIONS THROUGH PANEL TOPS.
2. TWENTY FOUR INCHES ON RIGHT SIDE OF SUPPORT PLANK (MEASURED FROM INSIDE EDGE OF RIGHT BEVEL) IS RESERVED FOR AUTODIALER OR FUTURE RTU AND ACCESSORIES.

BACK VIEW OF L.S. CONTROL PANEL

## LIFT STATION CONTROL PANEL NOTES

1. ALL WORK SHALL BE PERFORMED IN ACCORDANCE WITH THE NATIONAL ELECTRIC CODE AND APPLICABLE LOCAL CODES. THE PANEL MAKER SHALL BE A U.L. LISTED SHOP.
2. THE CONTROL PANEL SHALL BE FURNISHED COMPLETELY ASSEMBLED AND WIRED WITH THE FOLLOWING MINIMUM FEATURES.
  - A. ENCLOSURE SHALL BE NEMA 4X 316 STAINLESS STEEL FITTED WITH A 3 POINT LOCKABLE LATCH AND ALUMINUM DEAD FRONT PANEL.
  - B. MAIN BREAKER MECHANICALLY INTERLOCKED WITH EMERGENCY POWER RECEPTACLE.
  - C. THERMAL MAGNETIC CIRCUIT BREAKERS INCLUDING SEPARATE CIRCUIT BREAKERS FOR CONTROL CIRCUITS, ETC.
  - D. NEMA RATED COMBINATION STARTERS (LESS THAN 20 HP) OR SOLID STATE REDUCED VOLTAGE STARTERS (20 HP OR GREATER) FOR EACH PUMP.
  - E. TRANSIENT VOLTAGE SURGE SUPPRESSOR.
  - F. PUMP CONTROL WITH ALTERNATOR.
  - G. RUN TIME METER FOR EACH PUMP.
  - H. HAND-OFF-AUTO SELECTOR SWITCH FOR EACH PUMP.
  - I. PUMP 1-PUMP 2-ALTERATED SELECTOR SWITCH.
  - J. PHASE MONITOR.
  - K. PUMP STOP (GREEN), PUMP RUN (RED), PUMP OVERLOAD/HIGH TEMP (WHITE), AND PUMP MONITOR MOISTURE (WHITE) LIGHTS FOR EACH PUMP.
  - L. CONTROL POWER ON (WHITE), HIGH LEVEL ALARM (WHITE) , LOW LEVEL ALARM (WHITE) LIGHTS.
  - M. ALARM STROBE AND HORN WITH SILENCE SWITCH LOCATED INSIDE PANEL.
  - N. TYPE GFCI 20 AMP, 125 VOLT DUPLEX RECEPTACLE.
  - O. AUXILIARY POWER RECEPTACLE COMPATIBLE WITH DISTRICT EQUIPMENT.
3. CONTROL SYSTEM CIRCUIT SHALL BE 120 VOLT WITHIN THE CONTROL PANEL AND 24 VOLT INTRINSICALLY SAFE TO THE WETWELL.
4. ALL CONNECTIONS TO THE STATION SHALL BE INTRINSICALLY SAFE.
5. WIRES AND CORRESPONDING TERMINALS SHALL BE NUMBERED. WIRING SHALL BE COLOR CODED TO DISTINGUISH PANEL WIRING OF DIFFERING VOLTAGES AND INCOMING FOREIGN CIRCUITS.
6. GROUND ALL ENCLOSURES AND EQUIPMENT IN ACCORDANCE WITH THE NATIONAL ELECTRIC CODE. ALL COMPONENTS SHALL BE SIZED PER NATIONAL ELECTRIC CODE.
7. THE CONTROL PANEL INTEGRATED INTERRUPT RATING SHALL BE EQUAL TO THE AVAILABLE FAULT CIRCUIT CURRENT AT THE POINT OF INSTALLATION WITH A MINIMUM OF 10,000 RMS SYMMETRICAL AMPS.
8. PROVIDE ONE OR MORE EXPLOSION PROOF JUNCTION BOXES BELOW CONTROL PANEL. MAKE CONNECTIONS OF IMMERSIBLE CABLES TO PANEL WIRING IN JUNCTION BOX USING TERMINAL BLOCK DESIGNED TO ELIMINATE POSSIBILITY OF ACCIDENTAL ARCING BETWEEN TERMINALS. PROVIDE SEPARATE TERMINAL BLOCKS FOR POWER AND CONTROL.
9. CONDUCTORS SHALL BE TYPE THHW INSTALLED COPPER. PANEL WIRING SHALL SHALL BE TYPE MTW.
10. CONDUIT SHALL BE UV RESISTANT SCH 80 PVC.



ST. LUCIE COUNTY  
WATER & WASTEWATER  
CONSTRUCTION  
STANDARDS

LIFT STATION CONTROL  
PANEL NOTES

DATE APPROVED: DECEMBER 2015

DRAWING NUMBER:

S-24

# REUSE WATER SYSTEM

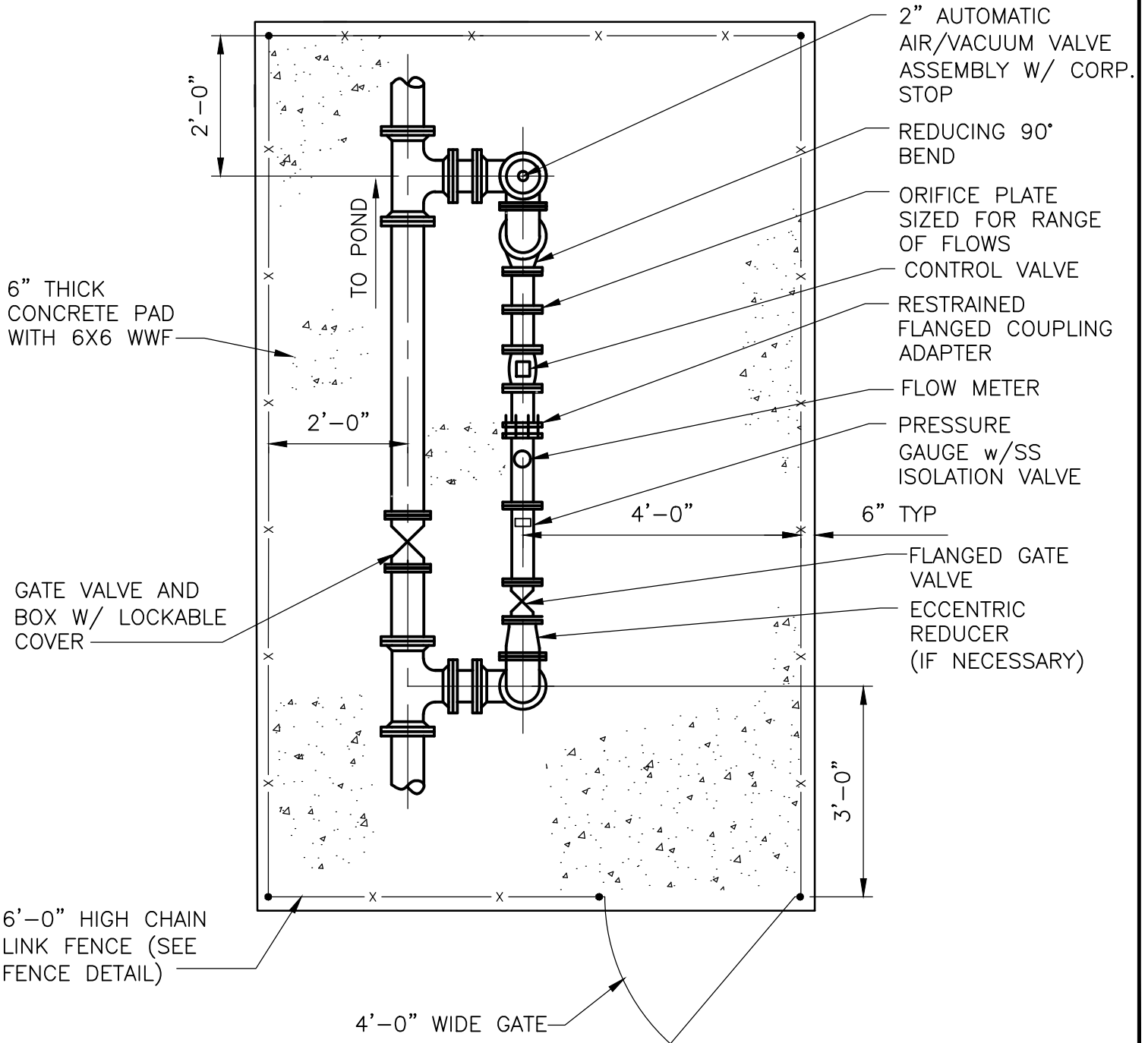

6" THICK  
CONCRETE PAD  
WITH 6X6 WWF

GATE VALVE AND  
BOX W/ LOCKABLE  
COVER

6'-0" HIGH CHAIN  
LINK FENCE (SEE  
FENCE DETAIL)

2" AUTOMATIC  
AIR/VACUUM VALVE  
ASSEMBLY W/ CORP.  
STOP

REDUCING 90°  
BEND

ORIFICE PLATE  
SIZED FOR RANGE  
OF FLOWS

CONTROL VALVE

RESTRAINED  
FLANGED COUPLING  
ADAPTER

FLOW METER

PRESSURE  
GAUGE w/SS  
ISOLATION VALVE

6" TYP

FLANGED GATE  
VALVE

ECCENTRIC  
REDUCER  
(IF NECESSARY)

# REUSE WATER SYSTEM

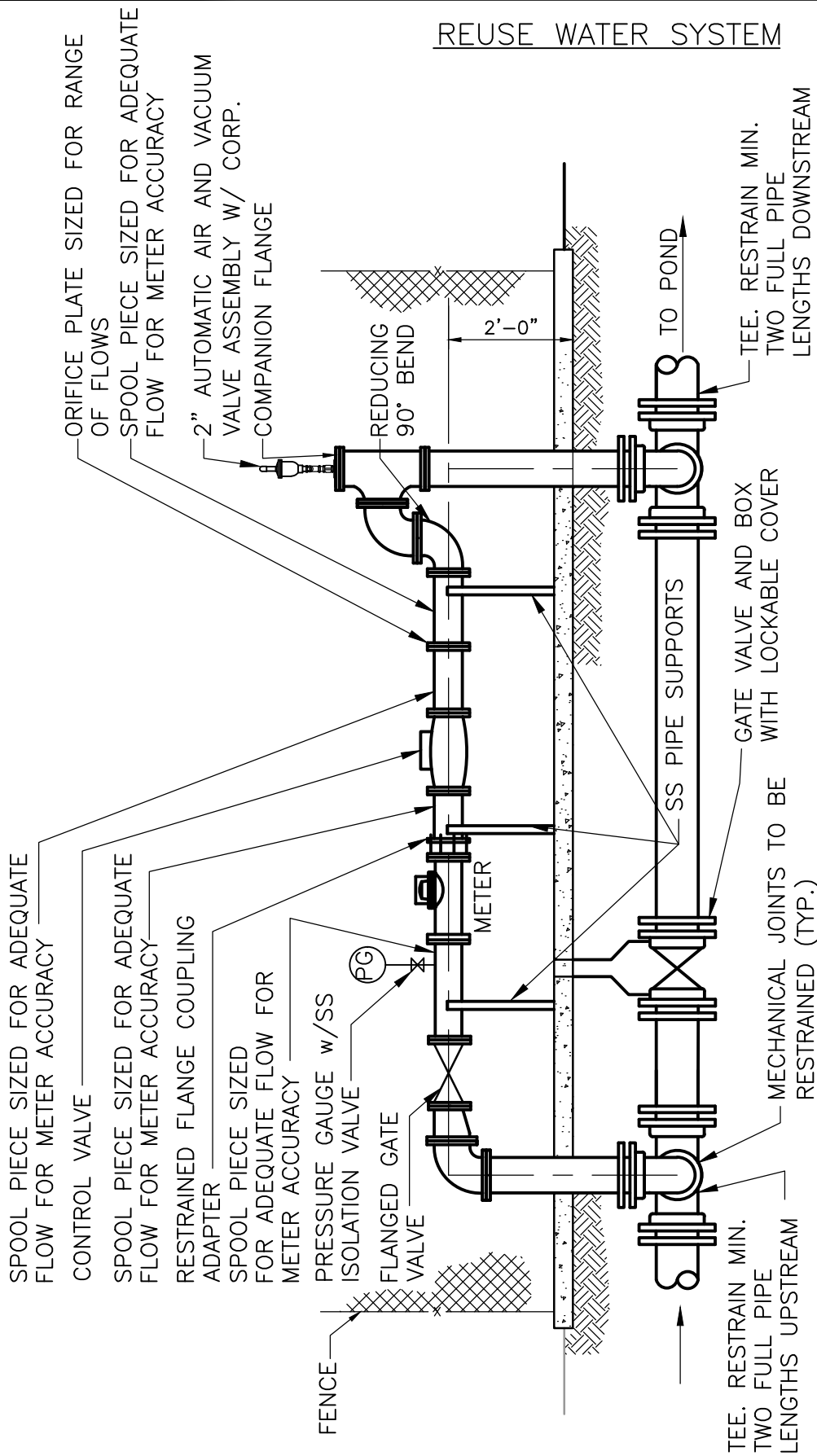

**NOTES:**

1. ALL FLANGED PIPE AND FITTINGS SHALL BE DUCTILE IRON, CEMENT LINED.
2. MECHANICAL JOINT FITTINGS REQUIRED BELOW GRADE AND FLANGED FITTINGS FOR ABOVE GRADE USE.
3. ALL ABOVE GRADE MATERIAL SHALL BE COATED PANTONE PURPLE WITH AN APPROVED COATING SYSTEM FOR EXPOSED METAL
4. ALL ABOVE GROUND BOLTING SHALL BE STAINLESS STEEL.
5. PIPE SHALL BE SIZED BY ENGINEER.
6. CONTROL VALVE SHALL BE GLOBE STYLE COMBINATION PRESSURE SUSTAINING WITH RATE OF FLOW CONTROL HYDRAULICALLY ACTIVATED VALVE.



ST. LUCIE COUNTY  
WATER & WASTEWATER  
CONSTRUCTION  
STANDARDS

REUSE WATER METERING FACILITY  
SECTION (POND DISCHARGE)

DATE APPROVED: DECEMBER 2015

DRAWING NUMBER:

RU-2

# REUSE WATER SYSTEM

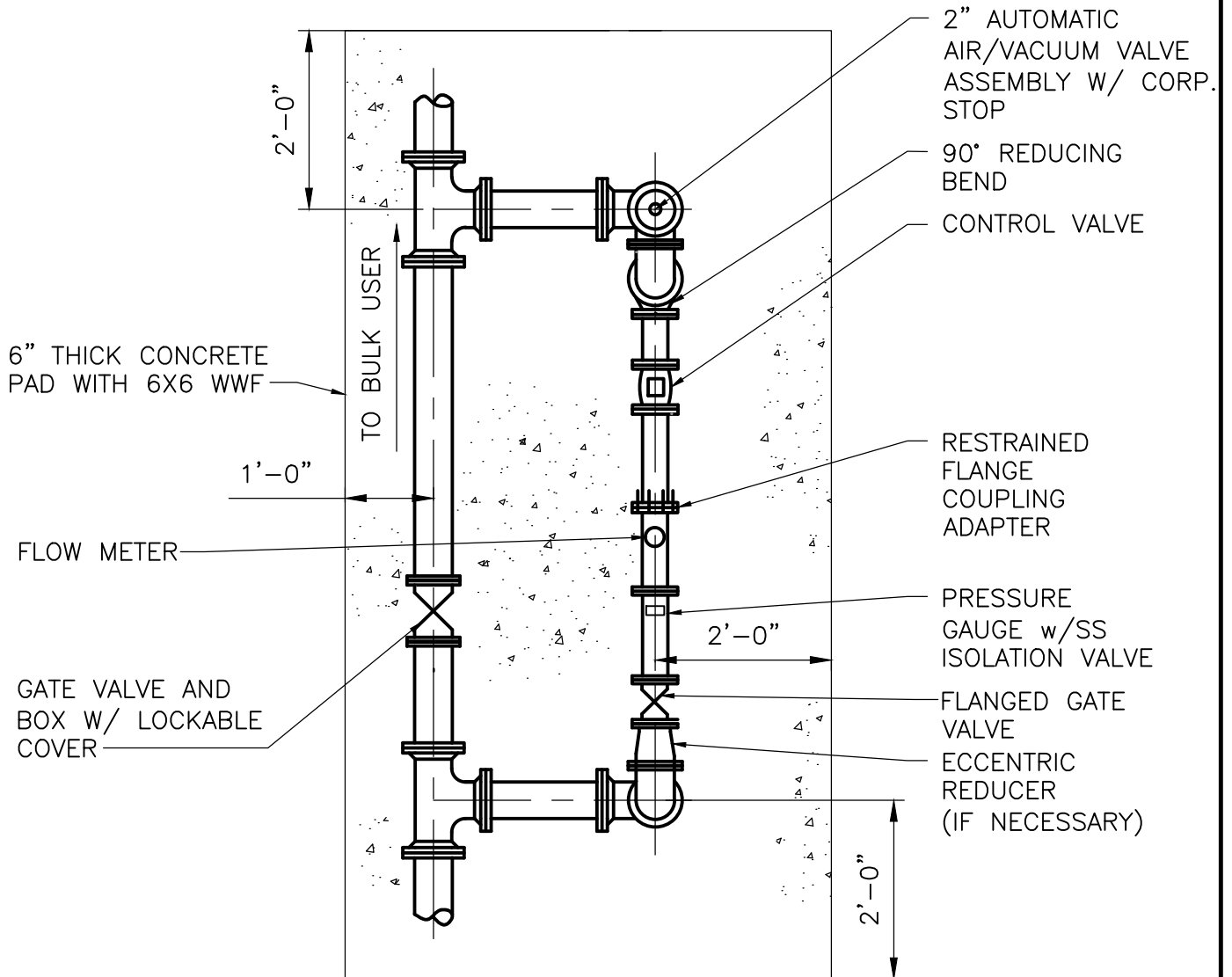



REUSE WATER SYSTEM

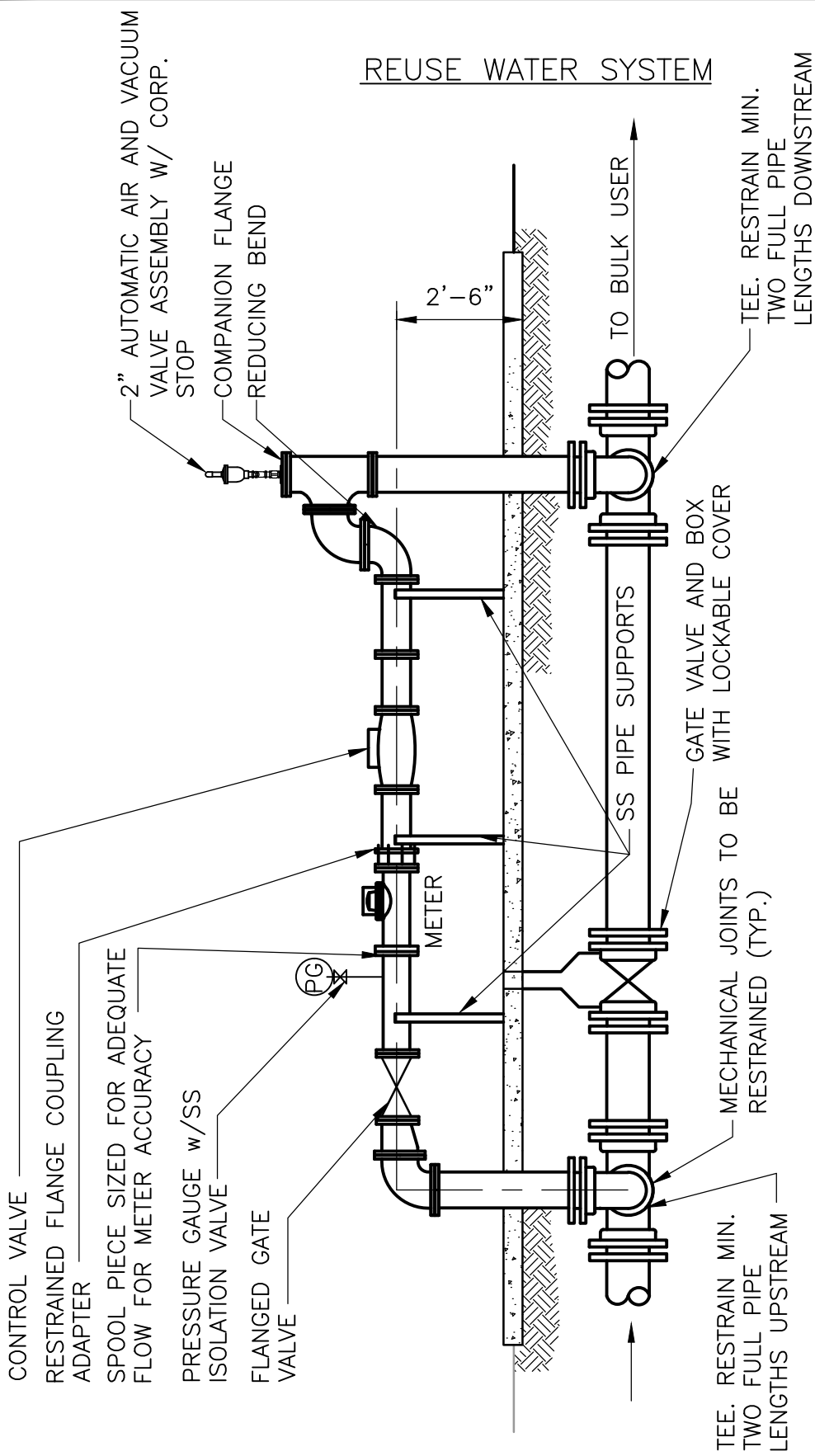

NOTES:

1. ALL FLANGED PIPE AND FITTINGS SHALL BE DUCTILE IRON, CEMENT LINED.
2. MECHANICAL JOINT FITTINGS REQUIRED BELOW GRADE AND FLANGED FITTINGS FOR ABOVE GRADE USE.
3. ALL ABOVE GRADE MATERIAL SHALL BE COATED PANTONE PURPLE WITH AN APPROVED COATING SYSTEM FOR EXPOSED METAL
4. ALL ABOVE GROUND BOLTING SHALL BE STAINLESS STEEL.
5. PIPE SHALL BE SIZED BY ENGINEER.
6. CONTROL VALVE SHALL BE GLOBE STYLE COMBINATION PRESSURE REDUCING AND PRESSURE SUSTAINING VALVE.



ST. LUCIE COUNTY  
WATER & WASTEWATER  
CONSTRUCTION  
STANDARDS

REUSE WATER METERING FACILITY  
SECTION (BULK USER)

DATE APPROVED: DECEMBER 2015

DRAWING NUMBER:

RU-4

## REUSE WATER SYSTEM

NOTE: FOR POSTING IN AREAS THAT  
IRRIGATE WITH RECLAIMED WATER

### **RECLAIMED WATER** Used for Irrigation



"DO NOT DRINK"

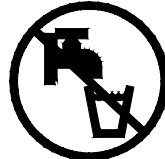

"NO BEBER"

A Water Conscious Community

### **LAKE CONTAINS RECLAIMED WATER**

"DO NOT DRINK"



"NO BEBER"



"DO NOT SWIM"



"NO NADAR"

A Water Conscious Community

NOTE: FOR POSTING AROUND STORAGE  
LAKES/PONDS THAT USE RECLAIMED WATER.

#### NOTES:

1. SIGNS SHALL BE 7"x10" (MINIMUM) .08 GAUGE ALUMINUM WITH WHITE BAKED ENAMEL FINISH AND VINYL LETTERING
2. MOUNT SIGN TO GALVANIZED U-CHANNEL SIGN POST.



ST. LUCIE COUNTY  
WATER & WASTEWATER  
CONSTRUCTION  
STANDARDS

REUSE WATER  
SYSTEM SIGNAGE

DATE APPROVED: DECEMBER 2015

DRAWING NUMBER:

RU-5